



Installation manual

Sandwich panels

CORE^{PIR/PUR} / CORE^{WOOL}

STEEL SERVICE CENTRE



Introduction

This document provides general recommendations and guidelines for the installation of wall and roof sandwich panels.

It has been developed for selected examples and is therefore not necessarily valid for all other scenarios possible during the installation of sandwich panels and flashings.

If the advice given conflicts with the conditions of a particular project (e.g. regarding unusual solutions), the installer should follow the guidelines of the construction project and the recommendations of the site manager.

STEEL SERVICE CENTRE

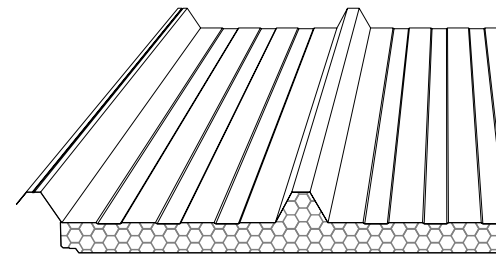
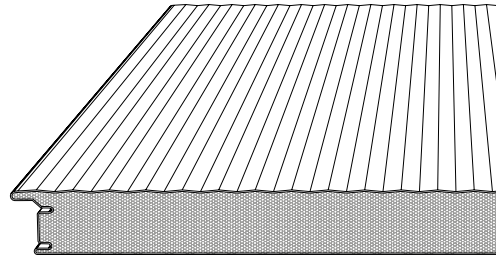
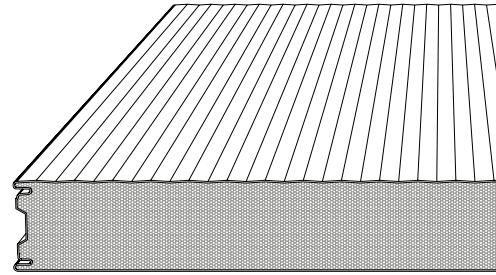

Table of Contents

1. Sandwich panels manufactured by VSS - description and basic properties
2. Transport, unloading and storage conditions of sandwich panels on site
3. Recommended tools and accessories for sandwich panel installation
4. General conditions for the installation of sandwich panels:
 - installation of wall panels
 - installation of roof panels
 - installation of flashings
5. Cleaning and maintenance of sandwich panels



THIS MANUAL IS FOR INFORMATIONAL PURPOSES ONLY AND DOES NOT RELEASE CONTRACTORS FROM THEIR RESPONSIBILITY TO FOLLOW THE RULES AND STANDARDS OF THEIR TRADE.

1. SANDWICH PANELS MANUFACTURED BY VSS - DESCRIPTION AND BASIC PROPERTIES



Wall panel with visible fastening

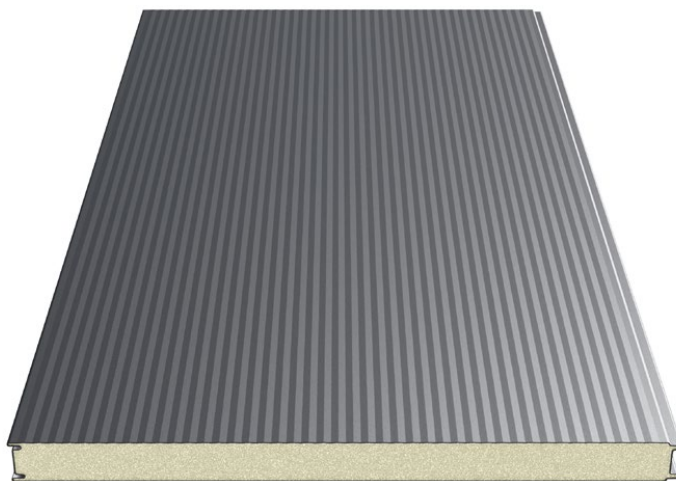

Panel cross-section

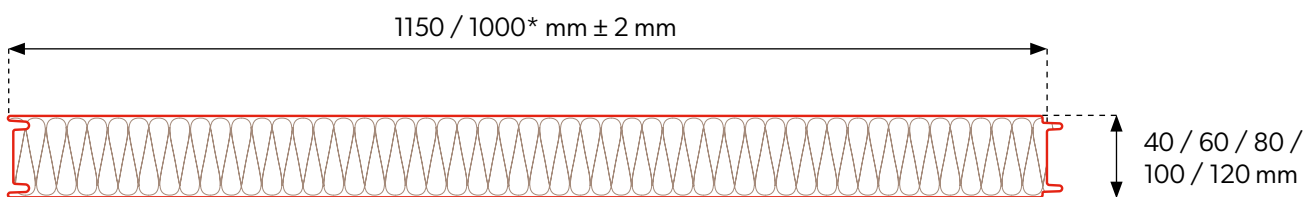

Joining the panels

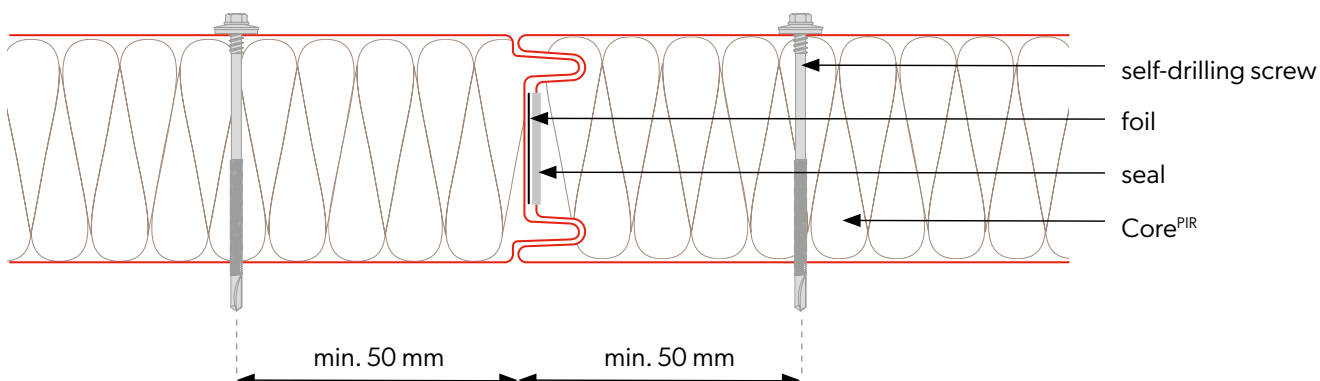

SPW-H CORE^{PIR}

Sandwich wall panel with concealed fixing

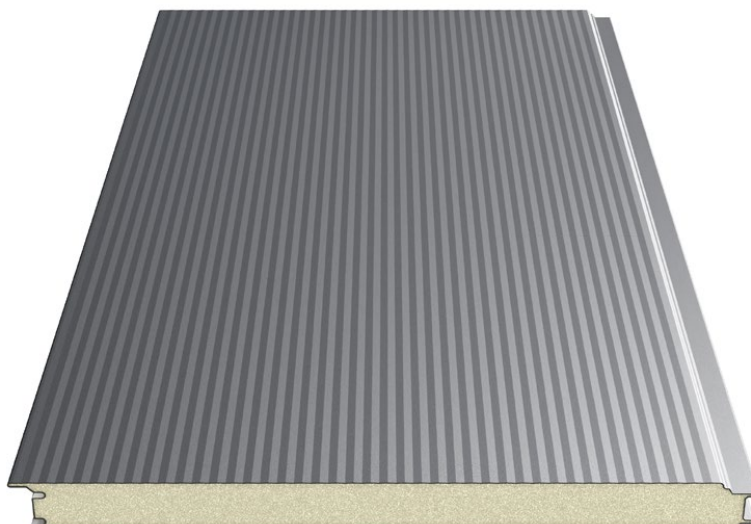

For the SPW-H wall panel with concealed PIR fixing, **WE RECOMMEND VERTICAL INSTALLATION.**

Panel cross-section

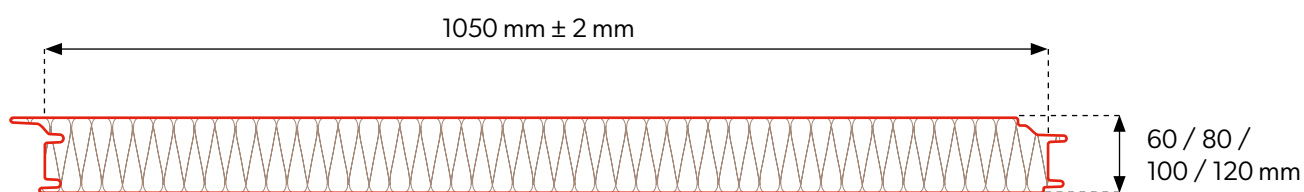

Joining the panels

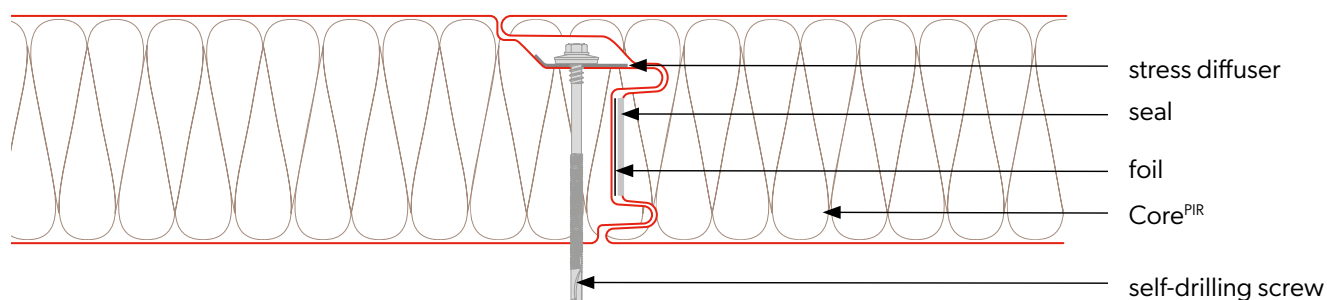

SPW-C CORE^{PIR}

Cooling sandwich panel

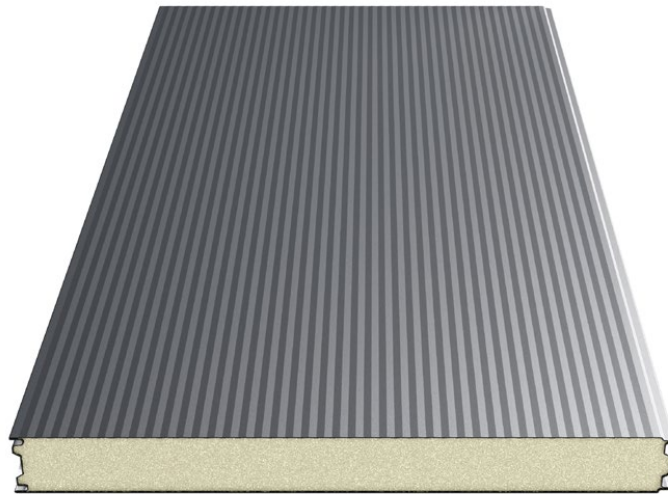

Panel cross-section

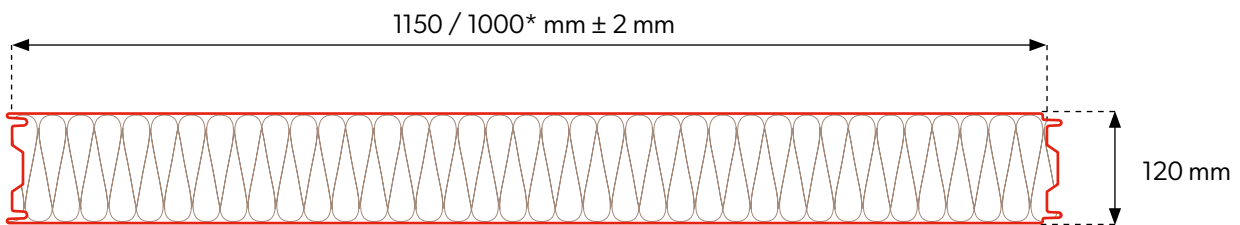

Joining the panels

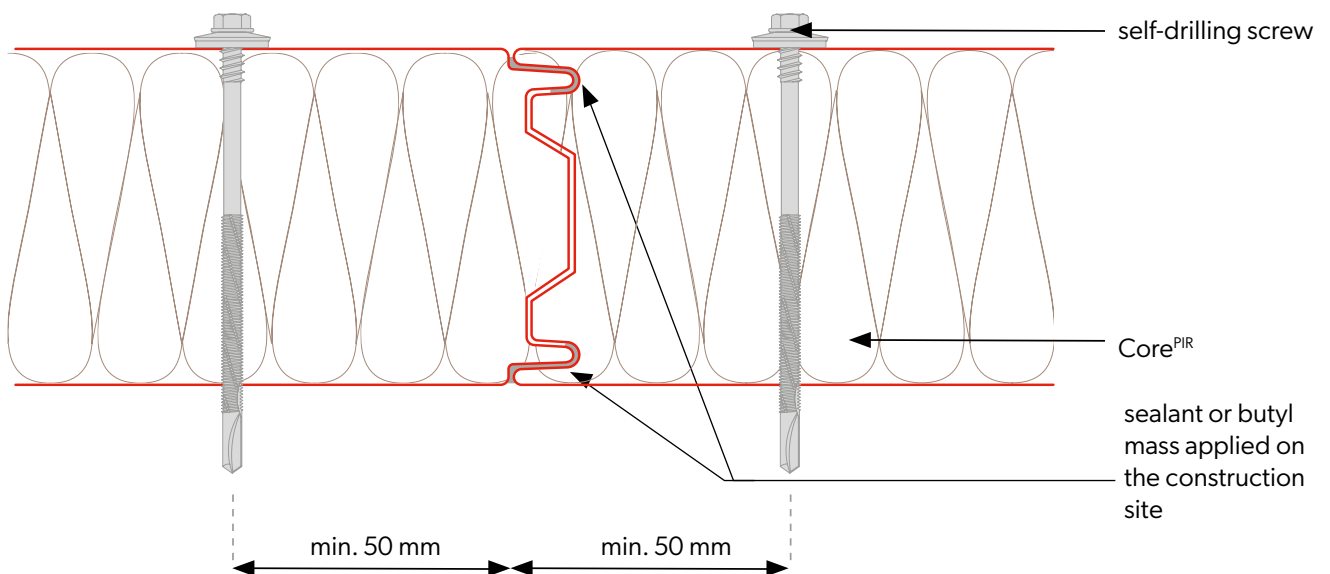

SPW-C CORE^{PIR}

Cooling sandwich panel

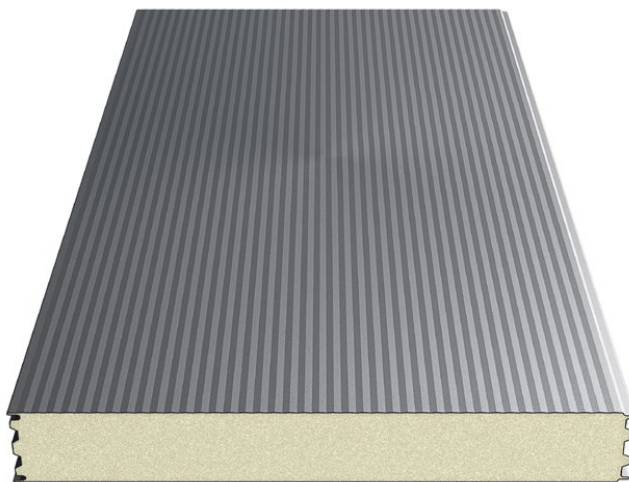

Panel cross-section

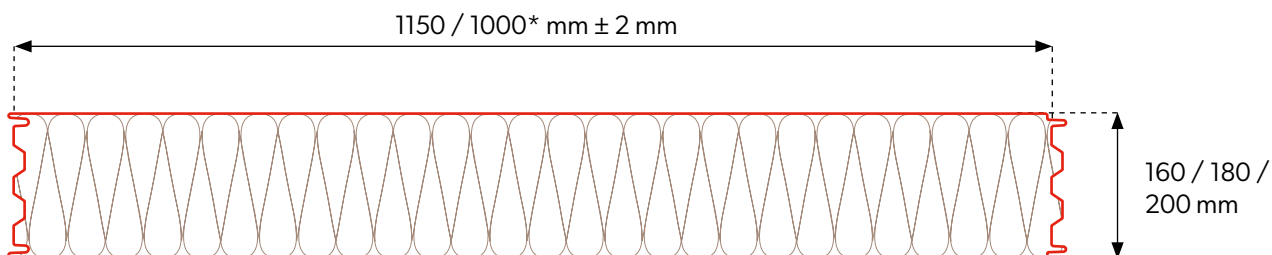

Joining the panels

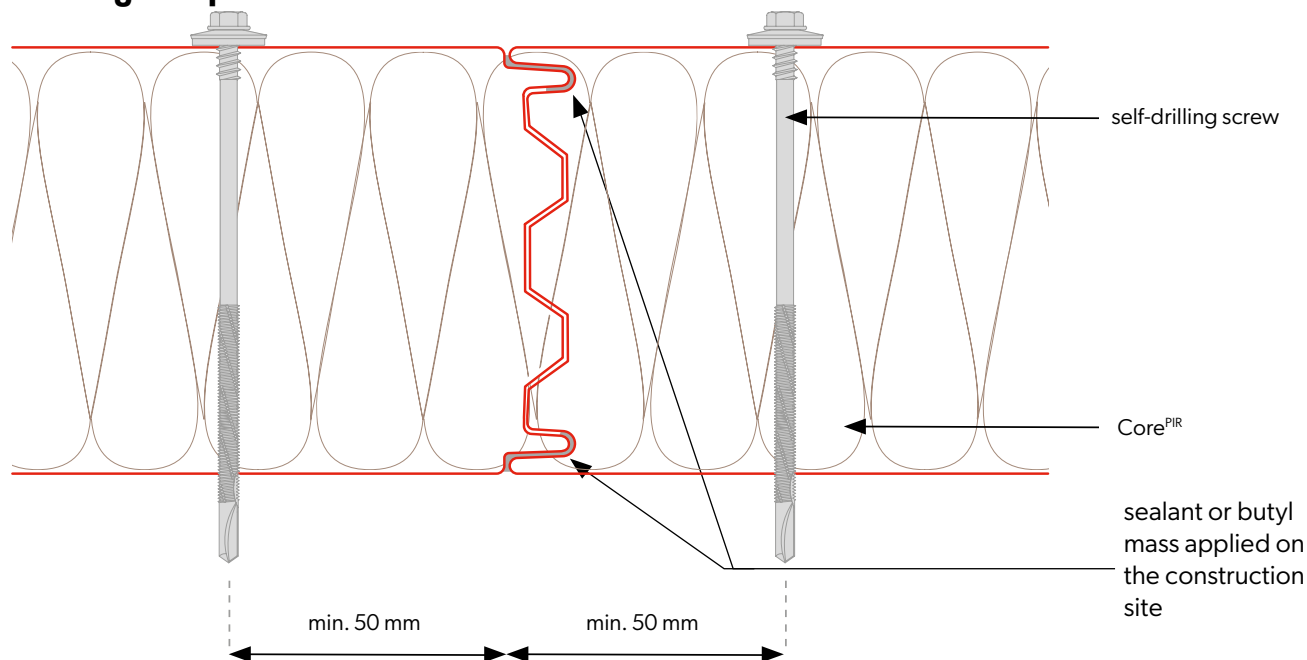

SPR CORE^{PIR}

Roof sandwich panel

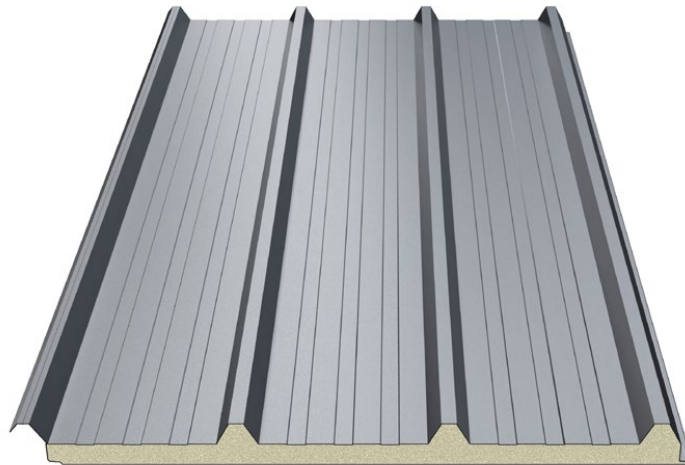

Panel cross-section

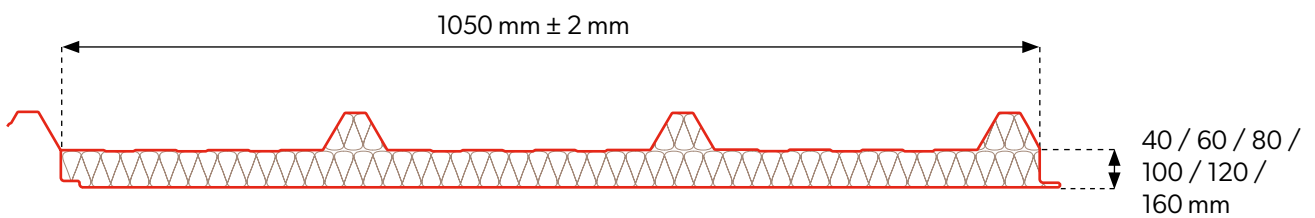

Joining the panels

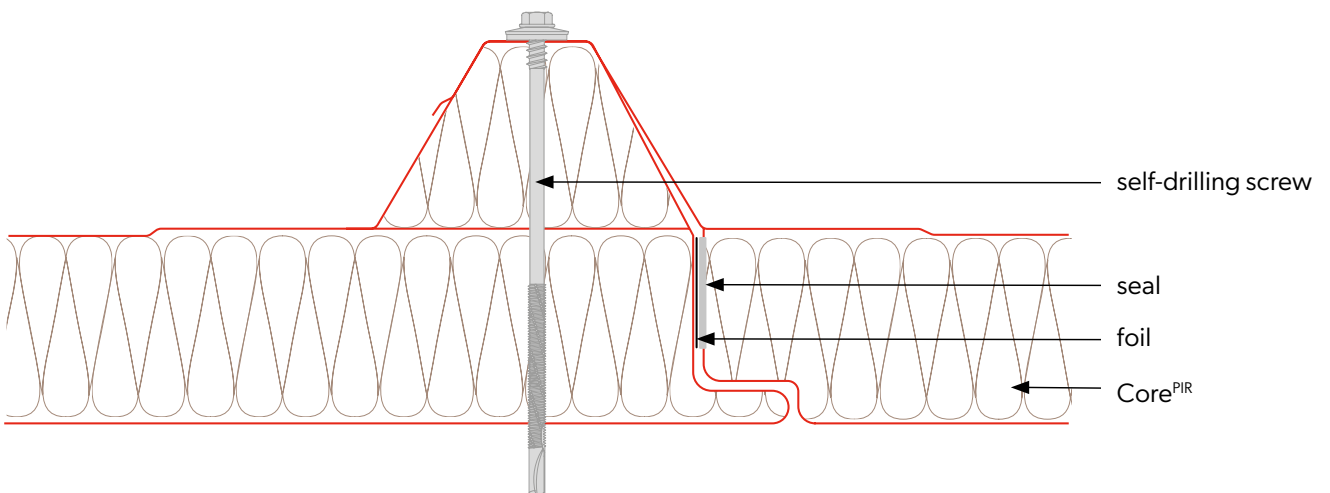

1. SANDWICH PANELS MANUFACTURED BY VSS - DESCRIPTION AND BASIC PROPERTIES



Wall panel with visible fastening

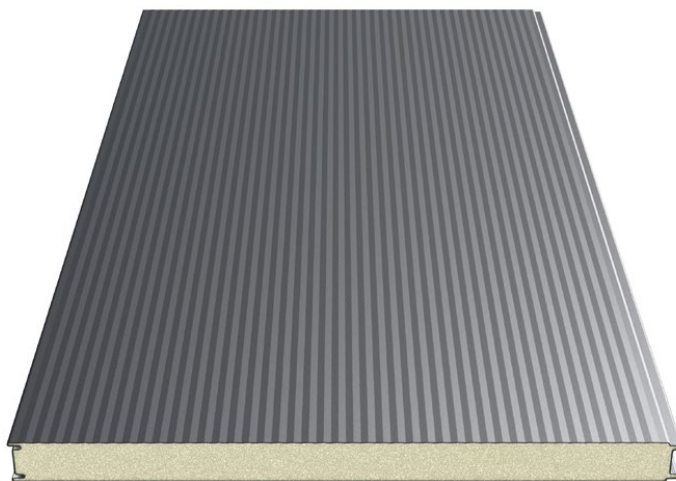

Panel cross-section

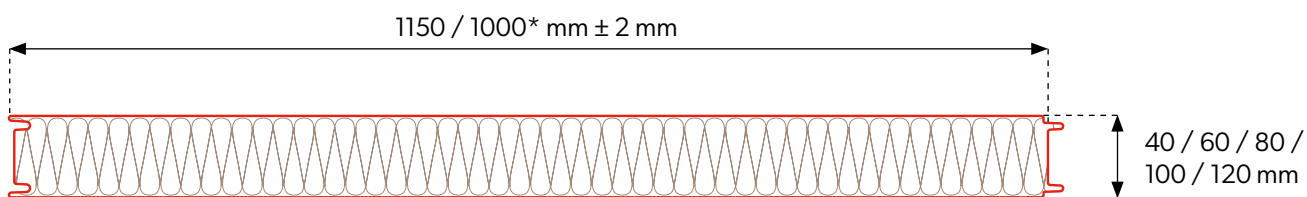

Joining the panels

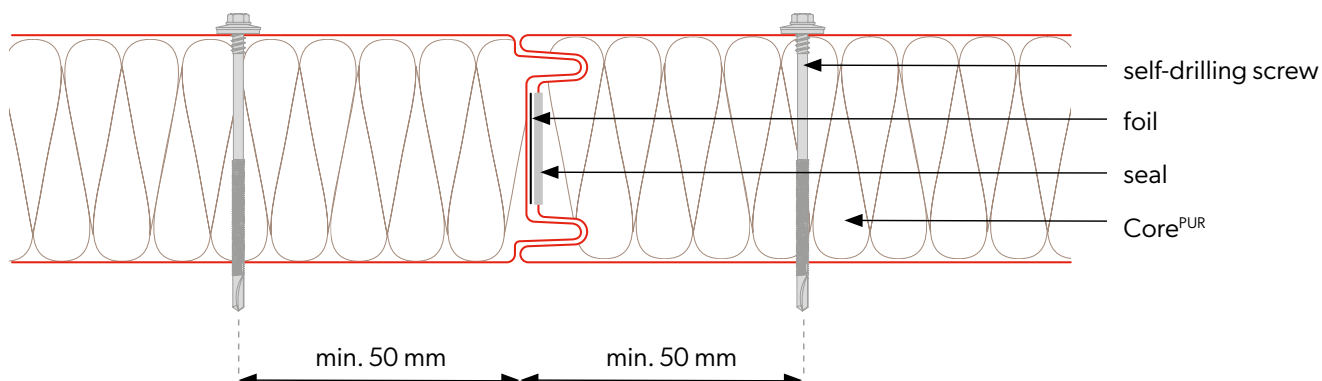

SPW-H CORE^{PUR}

Sandwich wall panel with concealed fixing

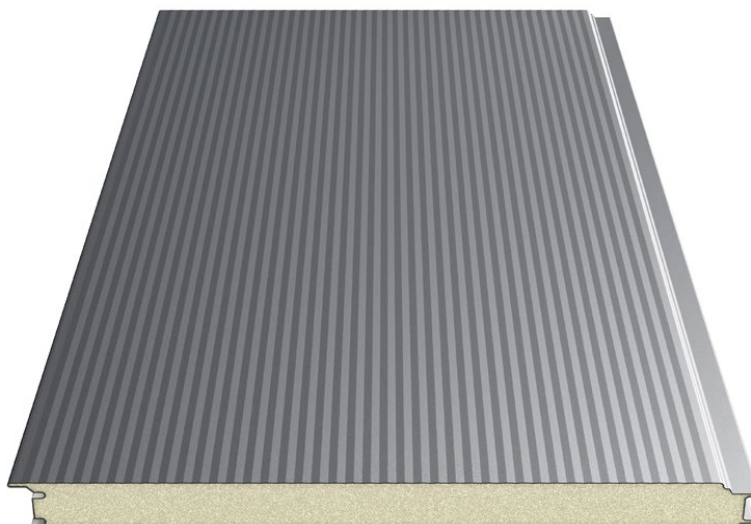

For the SPW-H wall panel with concealed PUR fixing, **WE RECOMMEND VERTICAL INSTALLATION.**

Panel cross-section

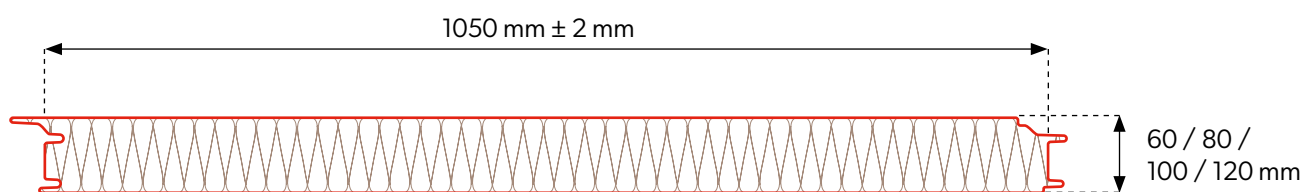

Joining the panels

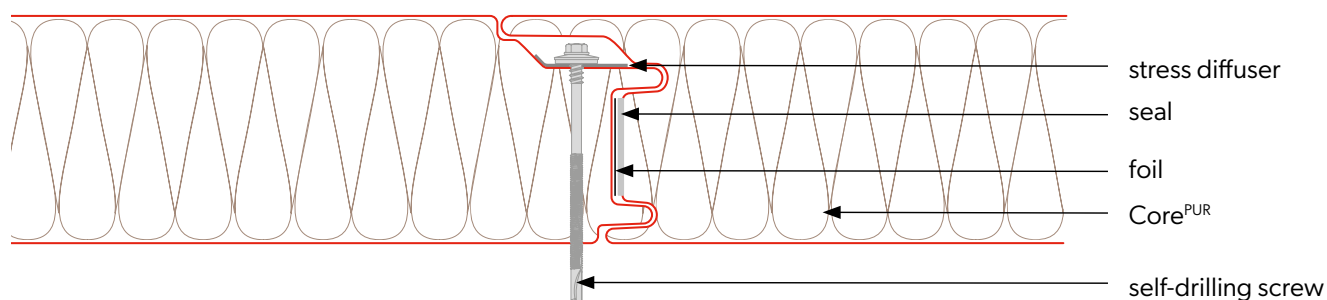

SPW-C CORE^{PUR}

Cooling sandwich panel

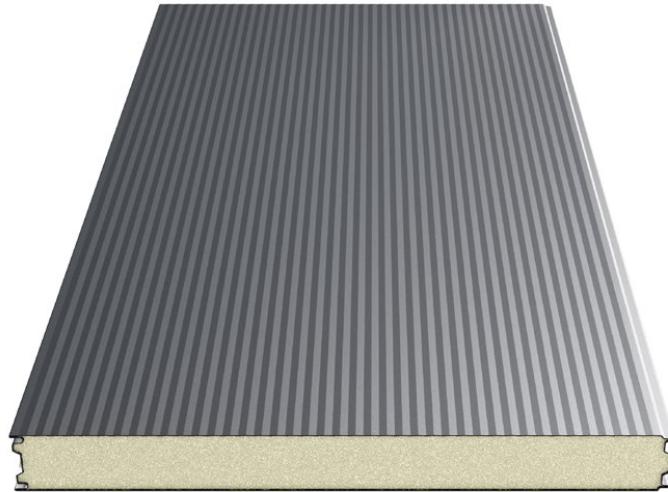

Panel cross-section

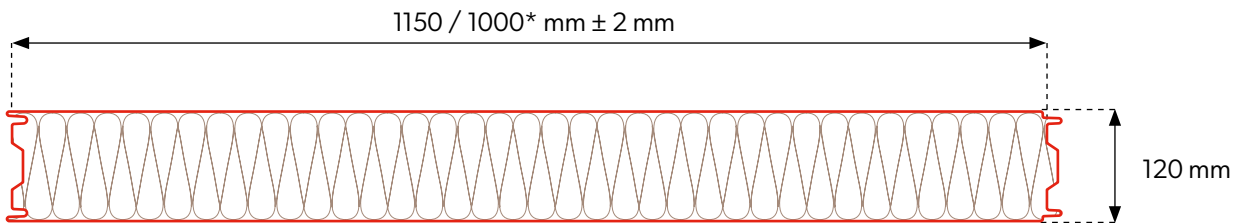

Joining the panels

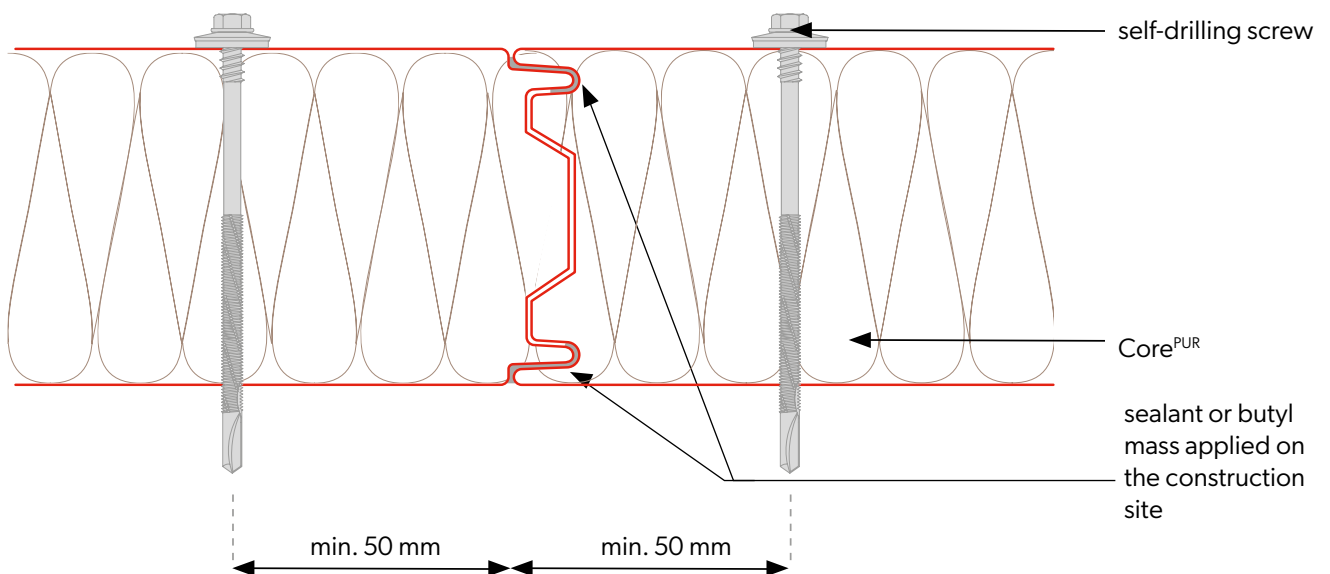

SPW-C CORE^{PUR}

Cooling sandwich panel

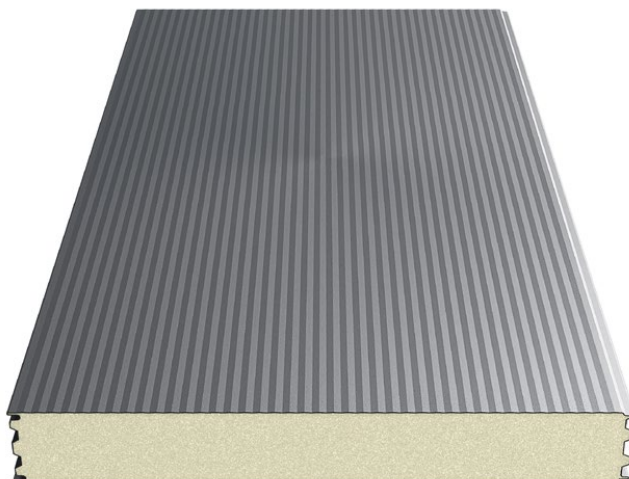

Panel cross-section

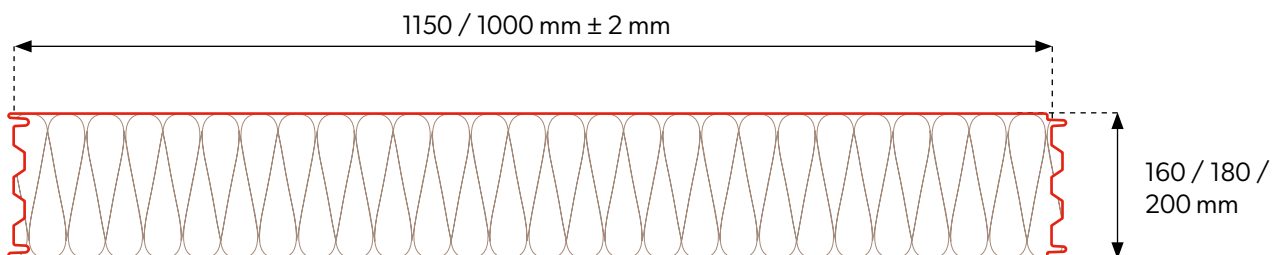

Joining the panels

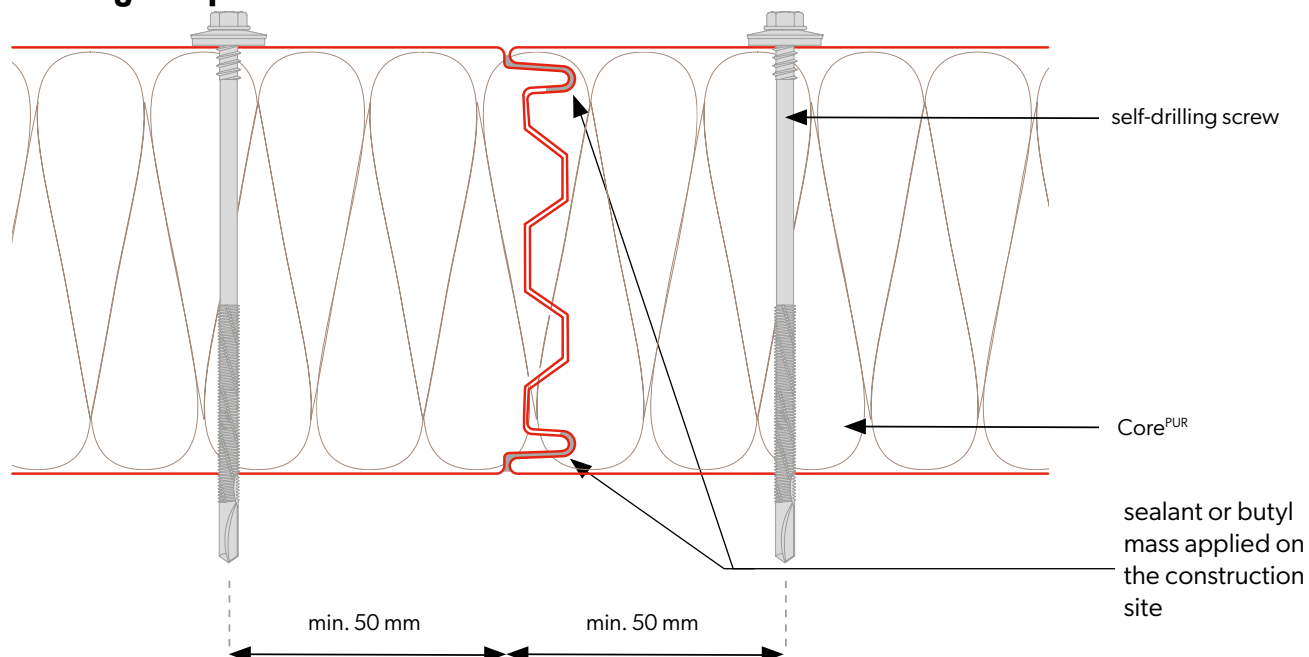

SPR CORE^{PUR}

Roof sandwich panel

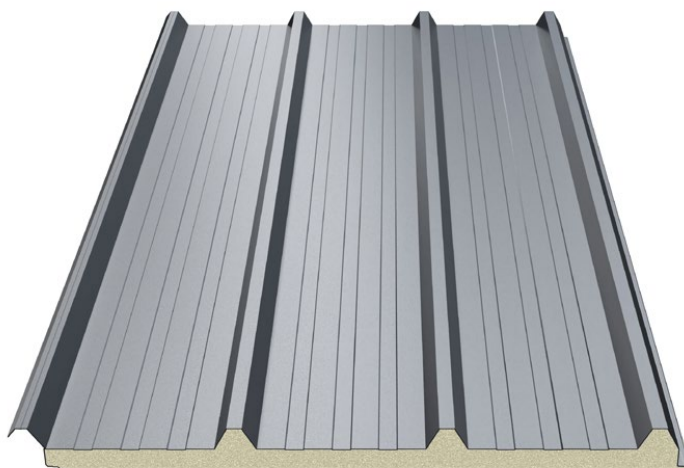

Panel cross-section

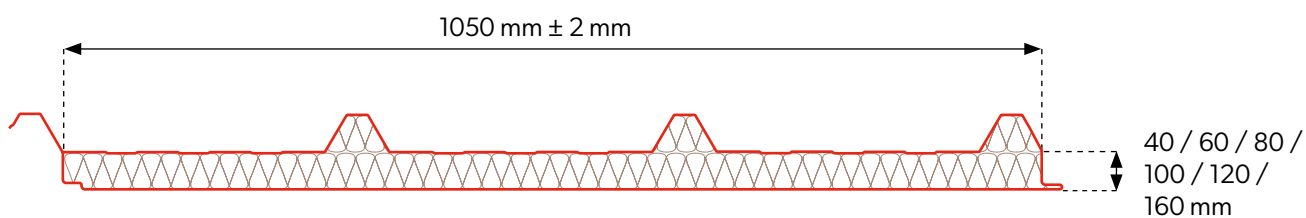

Joining the panels

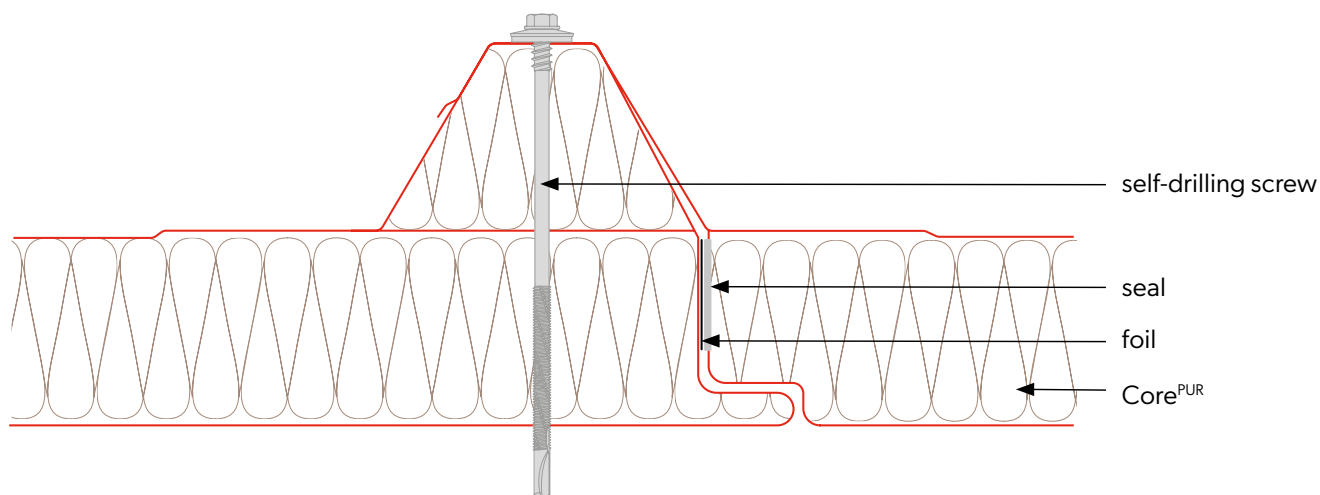

SPW-S CORE^{WOOL}

Wall panel with visible fastening

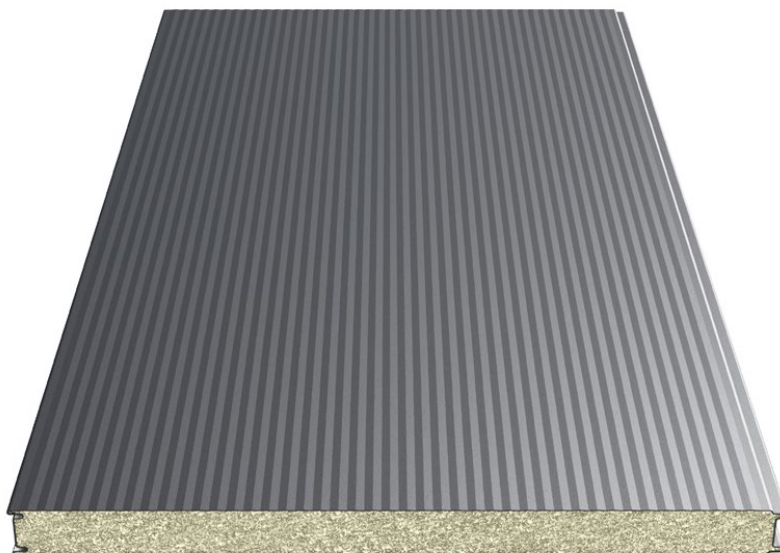

Panel cross-section

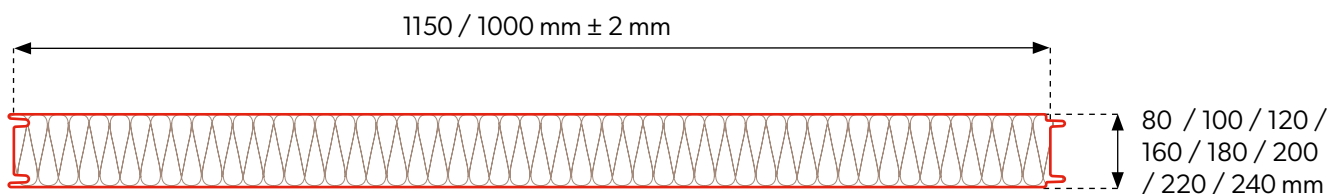

Joining the panels

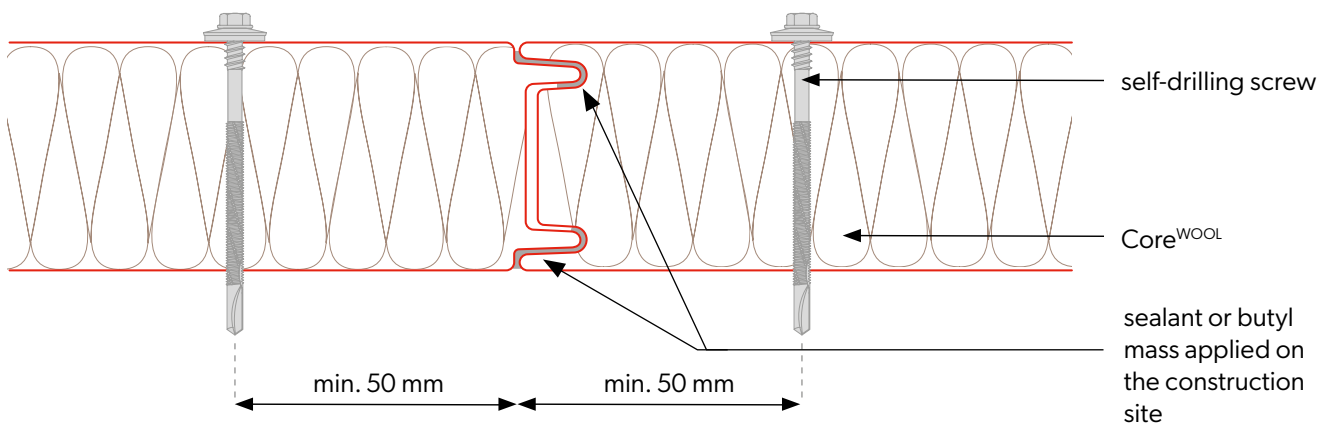

SPW-SM CORE WOOL

Wall panel with visible fastening

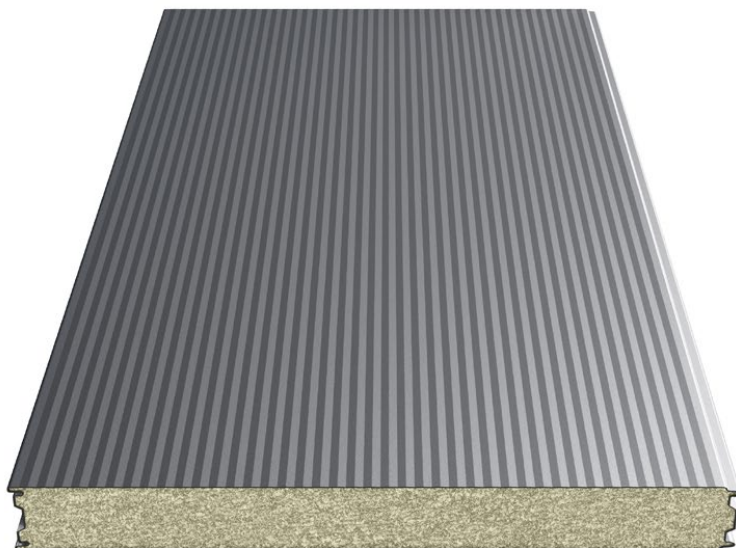

In the case of SPW-SM CORE WOOL panels with a thickness of 120-240 mm, the core joints are milled in the locks

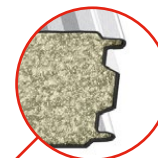

Panel cross-section

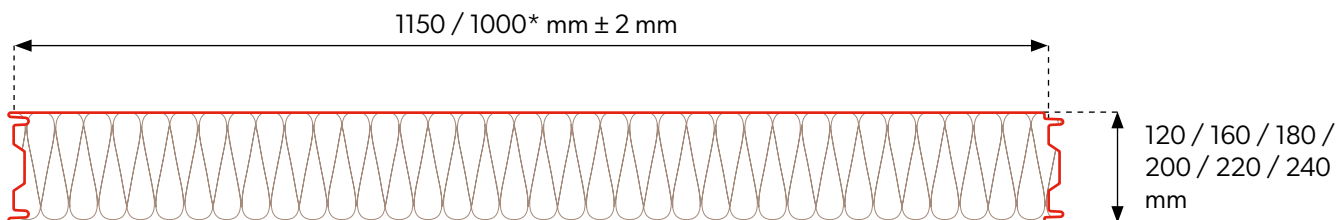

Joining the panels

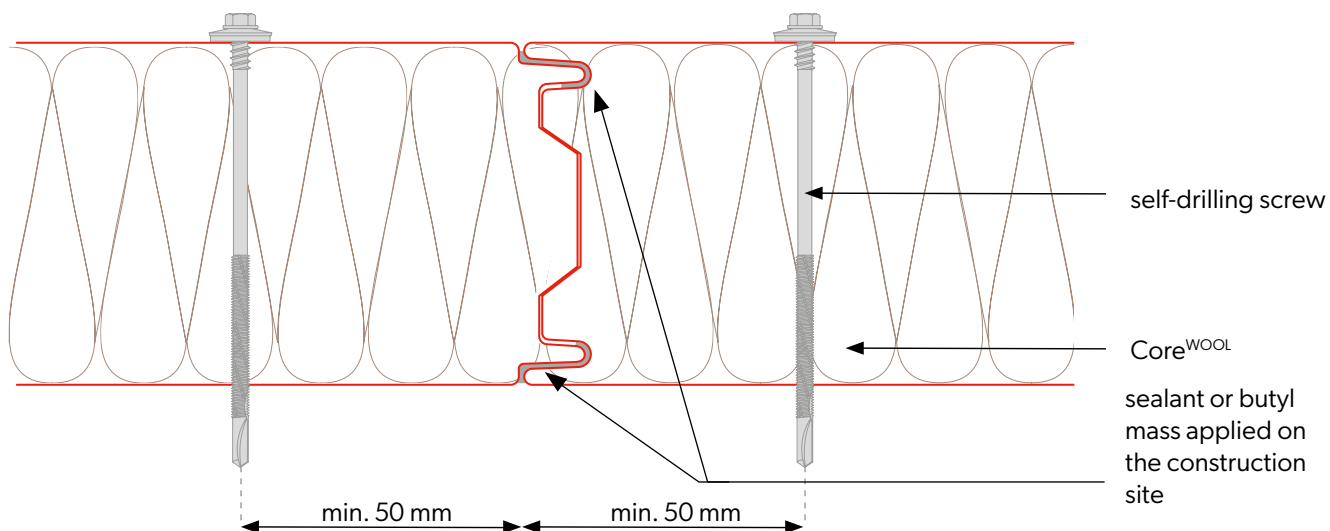



Roof sandwich panel

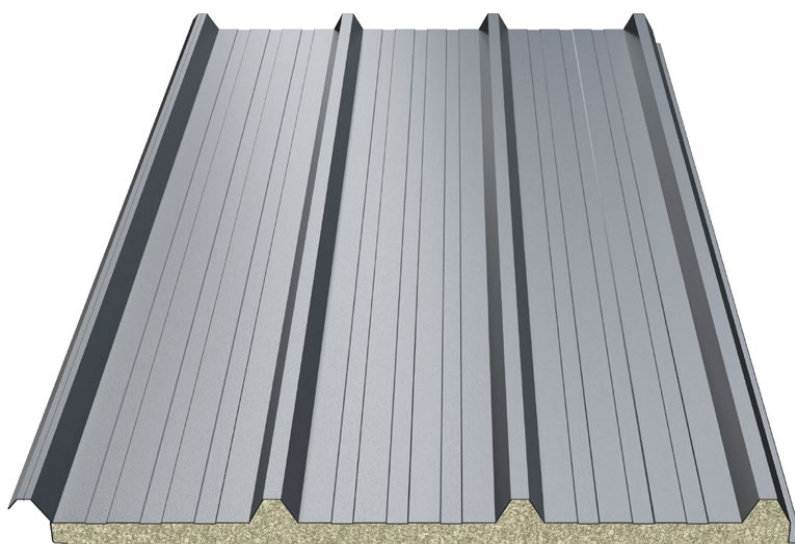

Panel cross-section

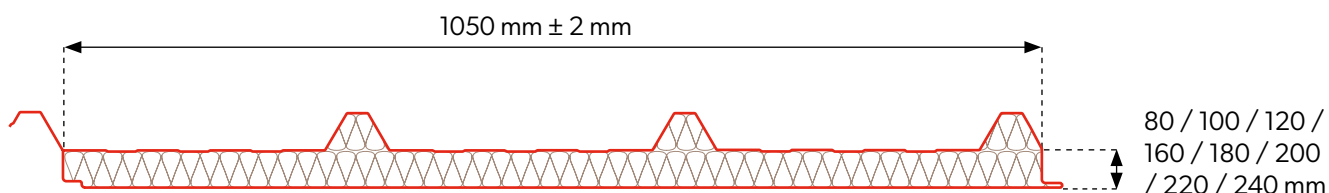

Joining the panels

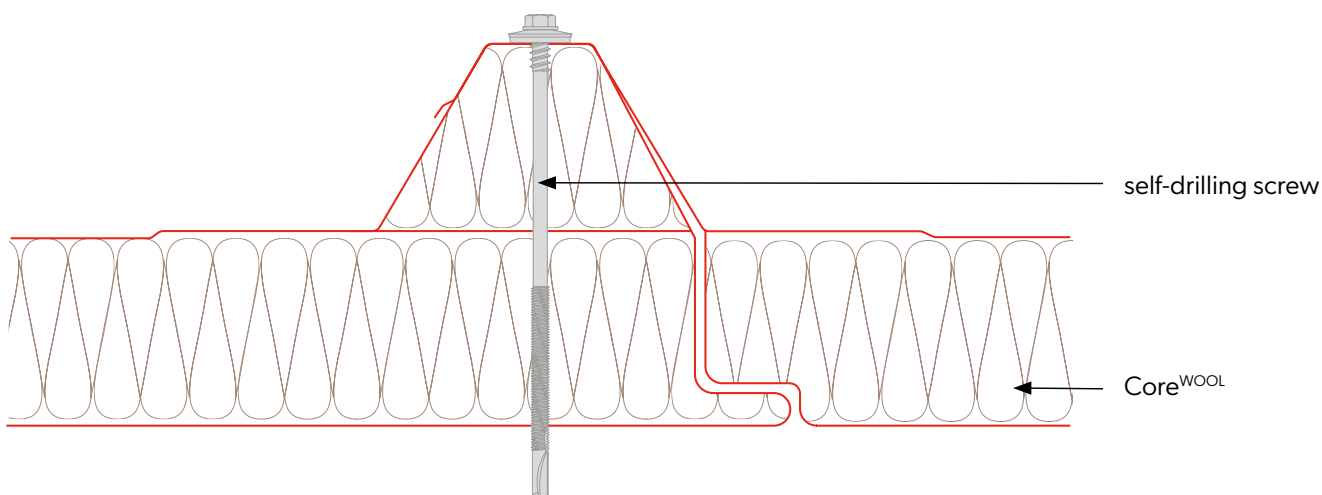

Wall sandwich panel

External profiling

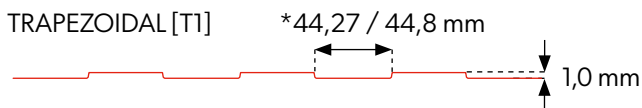
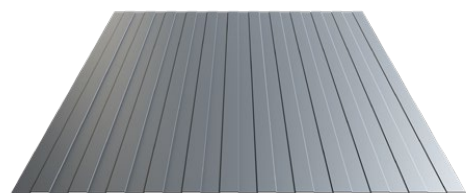
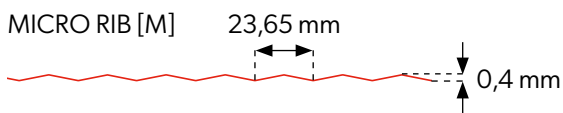
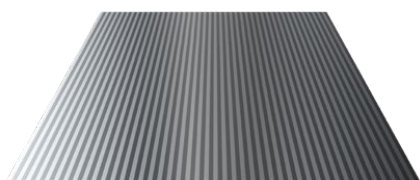

*44,27 mm - Panels with visible fastening
44,8 mm - Panels with concealed fixing

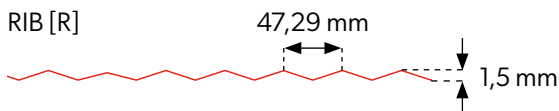
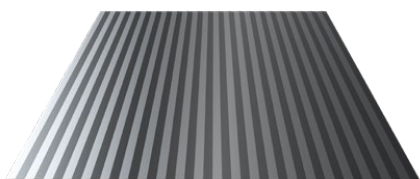

FLAT [F]

Internal profiling

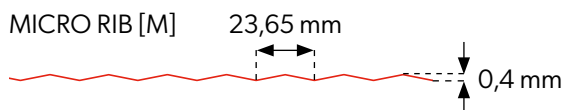
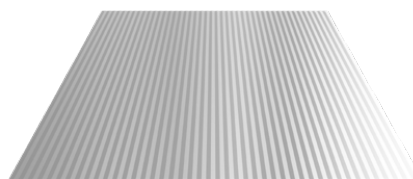
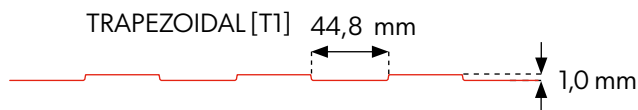
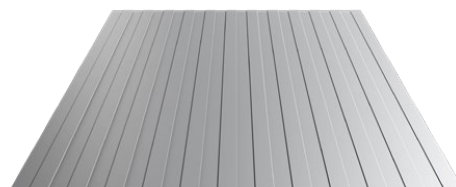

FLAT [F]



ATTENTION! Due to the structure of sandwich panels with FLAT [F] profiles, the so-called „waving“ effect of the sheet metal may occur. This is a natural phenomenon for this type of products. We recommend contacting the technical department to choose the optimal solution.



Internal and external profiling is available in any configuration.

Roof sandwich panel

External profiling

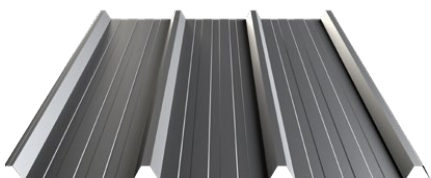

TRAPEZOIDAL 40 [T40]

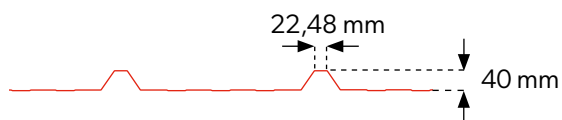

Internal profiling

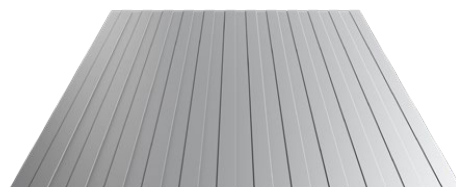

TRAPEZOIDAL [T1]

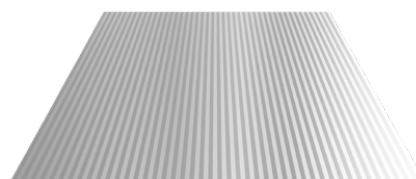
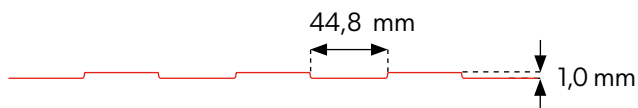

MICRO RIB [M]

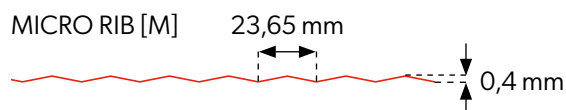

FLAT [F]



ATTENTION! Due to the structure of sandwich panels with FLAT [F] profiles, the so-called „waving“ effect of the sheet metal may occur. This is a natural phenomenon for this type of products. We recommend contacting the technical department to choose the optimal solution.



Internal and external profiling is available in any configuration.

The figure shows the maximum dimensions of a single package.

Maximum package dimensions:

- [1] max. 1.19 m
- [2] max. 1.25 m
- [3] max. 13.5 m

Fig. 01

Fig. 01

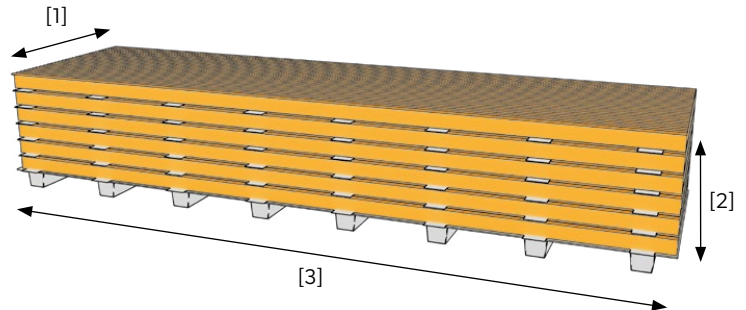

To transport sandwich panels, it is recommended to use a truck with an open trailer or one that allows side loading on both sides over its entire length. The trailer must not be shorter than the length of the panels to be loaded, and the weight of the load must not exceed the vehicle's capacity. Transport straps should be placed on the load at maximum 3 m intervals, but no less than 2 straps per package. Stretch belts cannot deform the panels.

Transport protection:

- [1] safety angle
- [2] transport straps

Fig. 02

Fig. 02

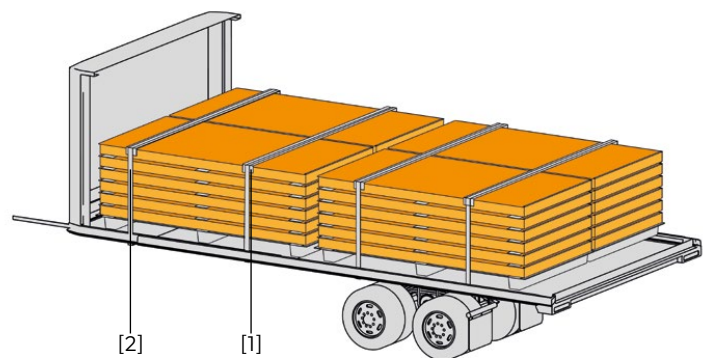

UNLOADING

The use of forklift trucks with adjustable fork widths is permitted for unloading packages with a maximum length of 6m. These, however, should have a minimum 2m spacing and a minimum width of 150mm. Packages longer than 6 m should be lifted using transport straps and traverses. For packages 6 - 12 m long, the straps should be at least 200mm wide and spaced every 2-4 m, while for those over 12 m, they should be respectively: 200 mm and 3.5-4.5 m. We recommend positioning the straps on wooden spacers placed at the bottom and top of a package. The straps should have a minimum width of 300mm and minimum thickness of 25mm. Do not lift packages on clamping straps, cross straps, or use steel cables or chains that may damage the goods.

Unloading (applies to packages 6-12 m long):

- [1] distance beam
- [2] distance from straps min. 5 cm
- [3] min. 200 mm strap width

Fig. 03

- Forklift:
- [1] polystyrene foam
 - [2] OSB board

Fig. 04

Acceptance and verification of delivered sandwich panels:

1. Qualitative and quantitative acceptance:

After delivery of the goods, the customer is obliged to conduct an acceptance inventory in the scope of:

- compliance of the quantity and dimensions with the order documentation,
- verification of product markings,
- technical condition of the delivered panels in terms of possible mechanical, transport or production defects.

2. Prohibition of installation of defective panels:

Sandwich panels that:

- have visible damage,
 - show other irregularities,
 - have been reported to the manufacturer for clarification,
- may not be installed until written confirmation from the manufacturer is obtained.**

3. Verification of panel geometry:

Before starting the installation, **the geometry of the sandwich panels should be checked in accordance with the requirements of the PN-EN 14509 standard** (or its current version). Particular attention should be paid to straightness, flatness, parallelism of the locks and dimensional tolerances.

Fig. 03

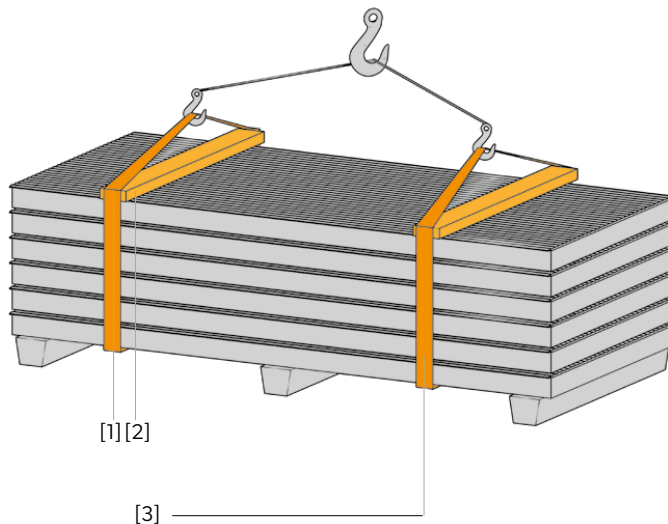
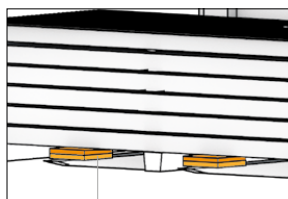
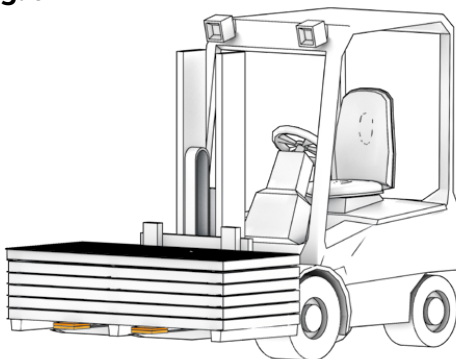

Fig. 04



[1][2]

STORAGE

At the construction site, we recommend storing the composite panel packages on the factory sleepers with a slight gradient of approx. 2 % along the side edge.

Fig. 05

Fig. 05

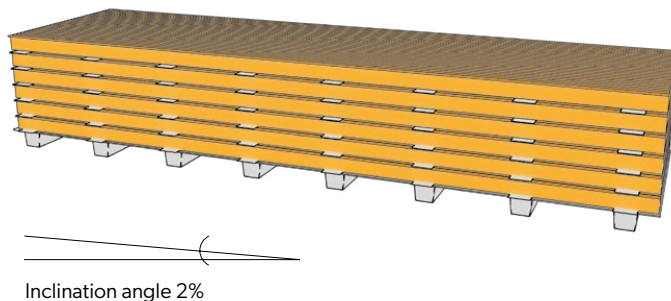

Packages must not be stacked as this can cause indentations and imprints on the facings. Sandwich panels should be stored indoors in a closed and well-ventilated place, but no longer than 4 weeks. Outdoor storage is only permitted for short periods and when protected from rain, strong wind, snow or any other contamination. For this purpose, we recommend using a tarpaulin that is permeable to air and allows moisture to escape.

Fig. 06, 07

Fig. 06



Fig. 07

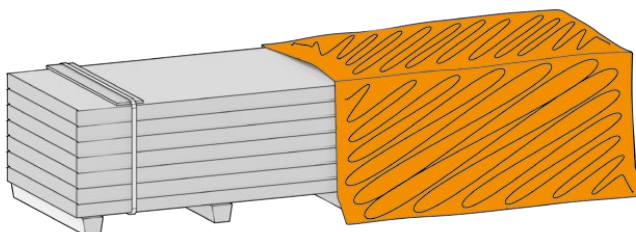

3. RECOMMENDED TOOLS AND ACCESSORIES FOR SANDWICH PANEL INSTALLATION.

Depending on site conditions, the following tools will be suitable for the installation of VSS sandwich panels.

For the fastener installation, it is recommended to use a specialised electric screwdriver equipped with suitable heads for screwing in long fasteners and adjusting the relative depth of the fastener head. It is also permissible to use a universal screwdriver equipped with adjustment of the relative depth of fastener embedding, with parameters:

- power: 600 ÷ 750 W,
- working rotations at this power:
1500 ÷ 2000 rpm,
- torque 600 ÷ 700 Nm.

A drill/driver (**fig. 09**), a tilting saw (**fig. 10**) and/or one of the commercially available slab saws (**fig. 11**).

Other tools include a spirit level, plumb bob and measuring tape.

Before starting the assembly, consult the project documentation to determine whether other tools will also be needed.

Fig. 09

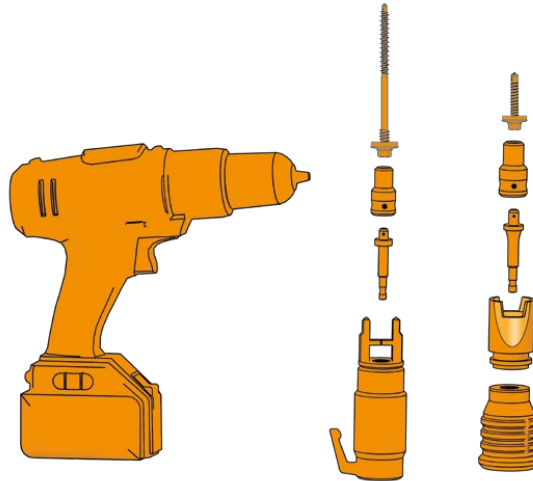

Fig. 10

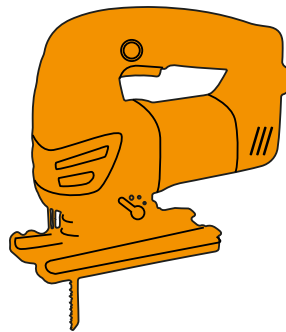
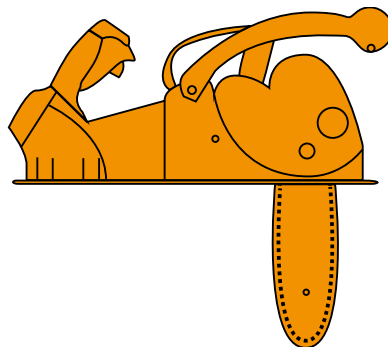

Fig. 11



Vacuum pads, designed for lifting wall and roof panels, are recommended for lifting and handling. When cutting the panels during the installation, use special shears, cutting tools, and saws that do not cause excessive heat in the cutting zone. High temperatures can damage the anti-corrosion coating in the cutting area. Therefore, it is important not to use a grinder for this purpose. Metal particles that appear after cutting should be removed immediately from the surface of the plate by the end of each working day. It is important to avoid scratching the protective coating with a nail or other sharp objects to prevent any damage to it.

Vacuum pads are ideal tools for the installation of roof and wall sandwich panels, as the suction cups allow safe and flawless handling of the panels. They speed up the assembly time and reduce the number of workers directly involved in the operation.

Fig. 12, 13

Fig. 12

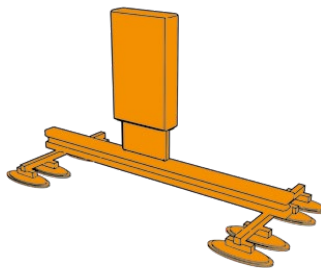
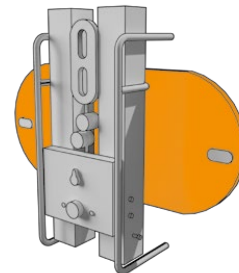

Fig. 13



Note! Angle grinders and other equipment that may cause excessive heat in the cutting zone, causing damage to the anticorrosion coating, are not permitted for cutting the panels and flashings.

Use hand shears to cut the flashings.



4. GENERAL CONDITIONS FOR THE INSTALLATION OF SANDWICH PANELS

1. Installation and atmospheric conditions



The proper installation of VSS sandwich panels is significantly affected by atmospheric conditions such as visibility, precipitation and wind. The installation should not be carried out in dense fog, rain, snow, hail or in winds exceeding 4° on the Beaufort scale, i.e. 9 m/s. The installation must be stopped if visibility deteriorates as a result of nightfall and if artificial lighting cannot be provided. It is recommended to carry out the installation work at temperatures between -5° C and 20° C, with the application of sealing compounds at ambient temperatures higher than 4° C.

2. Sandwich panel installation versus health and safety



Installation of VSS sandwich panels and all work carried out during the installation must be carried out under the supervision of authorised persons, in accordance with the current health and safety regulations for the installation and roofing work.

In addition, the following fall protection devices must be used when installing the panels:

- ropes and safety belts,
- safety barriers to be secured around the perimeter of the building,
- surveillance cameras.

3. Laying and unloading sandwich panels from a package

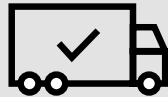

• When taking up from the pack and laying VSS roof panels, the use of a crane is recommended. However, the slope of the roof must be taken into account as there is a risk of damage to the edges of the panels.

- The lightweight panel can be taken from the pack and laid on the roof by hand.
- The protective film must be removed from the inner lining of the panel before taking an individual panel from the package and placing it on the structure.
- Workers carrying out the installation must wear protective footwear with a soft sole when walking on the slabs so as not to damage them.
- For VSS roof sandwich panels with a mineral wool core, a butyl sealant should be applied to the panel lock to prevent air and moisture ingress. The use of silicone for sealing is prohibited, especially silicone with an acidic reaction.
- To protect the seals, displacements in the longitudinal axis should be kept to a minimum.

4. Cutting and trimming sandwich panels



For cutting VSS sandwich panels, it is recommended to use fine-toothed saw blades or special metal circular saws provided they are equipped with sufficiently accurate guide systems. Cutting filings must be removed immediately from the surface of the panel.

Angle grinders and other equipment that may cause excessive heat in the cutting area, causing damage to the anticorrosion coating, are not permitted for cutting the panels and flashings.

Only hand shears should be used to cut all flashings.

- Sandwich panels should be cut, fitted and trimmed before the installation, on racks lined with soft material to protect their surface from damage.
- The indentations weaken the panels, so these areas should be adequately stiffened.
- The edges of panels and flashings cut on site must be protected immediately after cutting. In addition, if the flashings are foiled, the protective film must be removed before the installation.
- Cutting sandwich panels and flashings on roofs, scaffolding, mechanical work platforms, etc. is not permitted.

5. Preparation for installation

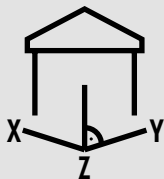

The following aspects should be checked before installing BP2 sandwich panels.

- Whether the substructure made of metal or concrete is in accordance with the design.
- Whether the primary and/or secondary structure of the walls is aligned and takes into account the spacing between columns (in the case of horizontal assembly) or between transoms (in the case of vertical assembly).
- Whether the spacing between the roof beams is maintained and flatness is checked when the roof beams are installed.
- Familiarisation with the technical details for the installation of sandwich panels.
- If there are any errors or discrepancies, inform the site manager and possibly the BP2 representative;
- Whether all the tools necessary for the installation are in stock.

It is important that the structure is properly prepared to facilitate the installation, ensure the correct operation of the fasteners holding the panel in place and give the building the right aesthetics. It is forbidden to carry out any welding work in the vicinity of the sandwich panels, as this may cause permanent damage to the anti-corrosion coating.

6. Protective film on sandwich panels

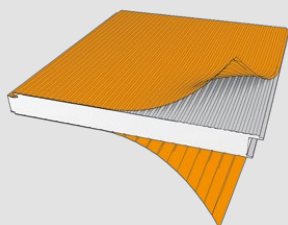

- BP2 sandwich panels are manufactured with a protective film to safeguard against dirt and damage. As standard, wall panels are foiled on one side (external cladding) while roof and wall panels with a smooth surface are foiled on both sides of the cladding. The protective film must be removed from the goods within 1 (one) month of production. The supplier is not responsible for the consequences of not removing the protective film.
- Peel off the protective film from the longitudinal edges before the installation.
- Where flashings, flanges, semi-circular or domed skylights or fogging systems are installed, the protective film should be removed from the inner cladding of the panel even before the installation.
- It is forbidden to leave a torn film after the installation, as this can lead to discolouration due to water run-off.
- Fitting the panels in a way that is not intended will invalidate the guarantee.
- On the side of the panel (lock pattern), the symbol **^INT^** is printed on the protective film to indicate the interior side of the board with Interior [INT] coating.

CORE PIR/PUR

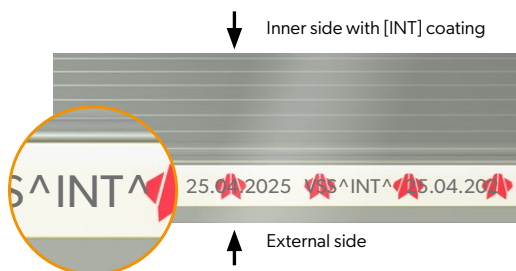

CORE WOOL

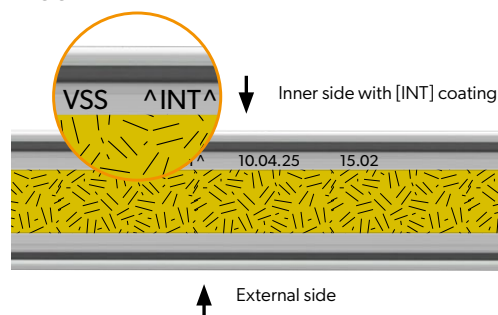

7. Fasteners for sandwich panel installation

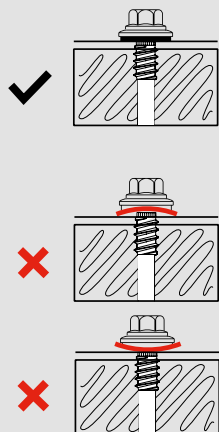

Use the manufacturer’s recommended self-drilling fasteners to fix BP2 sandwich panels to the supporting structure. The type of fastener depends on the type of supporting structure and the thickness of the panel to be installed. In order to properly fix the panel to the structure, the perpendicular position of the fastener must be maintained during embedding. Therefore, the use of specialised screwdrivers equipped with a guide head for long fasteners is recommended. Stainless steel self-drilling fasteners should be used when fixing panels in facilities where:

- interior atmosphere is characterised by permanent relative humidity (above 70%),
- interior atmosphere is chemically aggressive,
- special care is required to protect stored equipment.

A special drill allows the sandwich panels to be conveniently fitted to the façade or roof without the need to drill holes in advance, and the use of a self-vulcanising EPDM membrane ensures that the joint is completely sealed. It is very important that the fastener adheres correctly to the panels during the installation: it must not be set too tightly or too weakly. The minimum recommended number of fasteners for a slab installed in a single-span scheme should not be less than 2 pieces. The number of fasteners must be determined by the building designer on a case-by-case basis, based on the loads adopted by the constructor. For multi-span schemes, it is advisable to calculate the number of fasteners for each support in each case.

8. General remarks on installing the panels



- The panels should be installed according to package numbering and production direction. This applies mainly to sandwich panels with cladding in metallic colours, i.e. REL 9006, RAL 9007. A 180° rotation of the panels can lead to colour differences;
- Guidelines for the installation of sandwich panels with dark-coloured cladding:

For the correct operation of installed sandwich panels, it is recommended to follow the guidelines specified by the manufacturer when designing and installing them on buildings in particular this applies to sandwich panels with dark-coloured cladding. This is controlled by EN 14509:2010, which divides the colours into 3 basic colour groups: very light, light and dark.

Colour group	Colours according to RAL
Group I - very light	1015, 7035, 9002, 9010
Group II - light	1002, 6011, 9006
Group III - dark	3000, 3005, 3009, 3011, 5010, 6005, 6020, 6029, 7016, 7024, 8004, 8017, 8019, 9005, 9007

For each colour that is in these groups, the temperature values for the external cladding of the sandwich panels are assigned and are respectively:

1. +55 °C for very light colours
2. +65 °C for very colours
3. +80 °C for dark colours.

When designing façade and roofs clad with sandwich panels in a specific colour scheme, temperature differences must be taken into account in the static calculation, assuming a base temperature for the external environment of +20°C. It is also recommended to avoid, when designing, multi-span layouts, which are very unfavourable for dark colours. For wall panels in colour group III, the maximum length should not exceed 9.5 m and for roof panels 13.5 m.

When installing sandwich panels in dark colours, it is recommended that the outside temperature should not be below 10°C.

Failure to meet all these conditions may impair the aesthetics of the sandwich panel cladding.

- For large areas, as the building work progresses, the colour consistency should be assessed on an ongoing basis from a distance of at least 25 m. The further away the person assessing the building is, the more visible even relatively small colour differences become. When installing panels with metallic-coloured facings, assessments should be made as often as possible and from different angles. Evaluation will be facilitated by removing the film on an ongoing basis.

- Because of the complexity of the technological processes, metal cladding manufacturers do not guarantee colour shade consistency from one delivery to the next. In order to avoid shade differences and to maintain the colour uniformity of the sandwich panel cladding, the purchaser should agree in writing with the BP2 representative prior to concluding the contract/ordering which part of the contract/order relates to the delivery to a specific site, indicate the division of the walls into axes and provide a delivery plan.

If a contract is concluded, BP2 undertakes to fulfil orders according to the axes sent from one batch of sheet production. Consideration should also be given to the possibility of a shade differences on the façade for panels of different thicknesses of sheet mounted on an axis. It is also recommended to use a single sheet thickness for all panel types on a given axis. Otherwise, BP2 is not responsible for any colour differences. If you have any questions, please contact your BP2 representative.

When combining BP2 sandwich panels from different production batches on the façade axis, peel off the protective film and check for shade differences immediately after installing a panel from a different production batch. If a difference in shade is evident, the installation work must be stopped and the BP2 representative must be notified immediately. Otherwise, BP2 is not responsible for any shade differences found during and after the installation of the sandwich panels.

INSTALLATION OF WALL PANELS

Start the installation of the sandwich panels by unloading and moving the panels to the installation site. This operation can be carried out manually when the panel is lightweight (**fig. 17**) or by using mounting tools to lift the panels. The top panel should be easily removed, allowing lifting equipment to be installed. The panel should not be moved as this could damage its metal surface. The protective film should be removed from the inner cladding of the panel before the installation.

- The use of a crane is recommended for unloading and laying VSS wall panels.
- When using a crane, use a strap with a length matched to the length of the panel.
- The wall panels can also be unloaded from their packaging and installed using a device with suction cups or other devices to lift the panels.

Fig. 14, 15, 16

Fig. 14

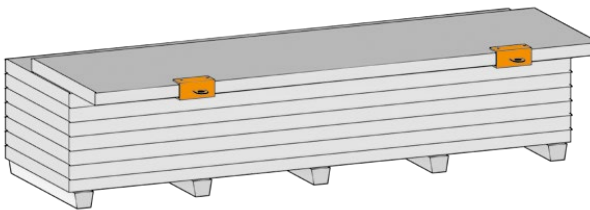

Fig. 15

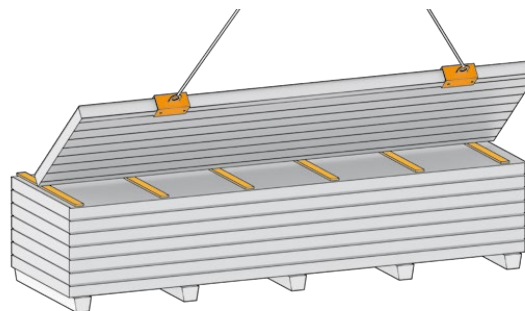
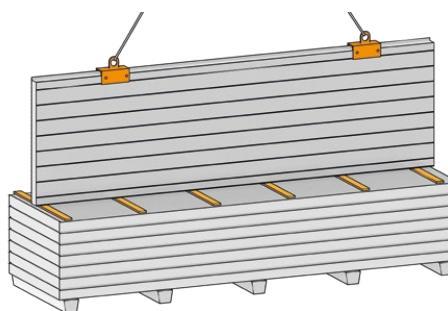

Fig. 16



- Panel with a low unit weight can be taken from the package and laid by hand.

Fig. 17

Fig. 17

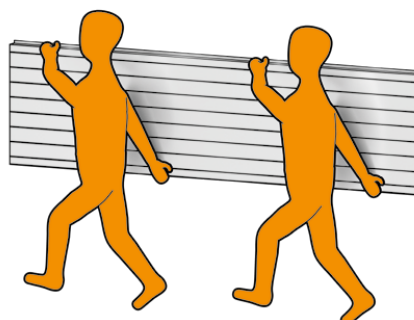

- The protective film must be removed from the inner lining of the panel before the installation;

Fig. 18

Fig. 18

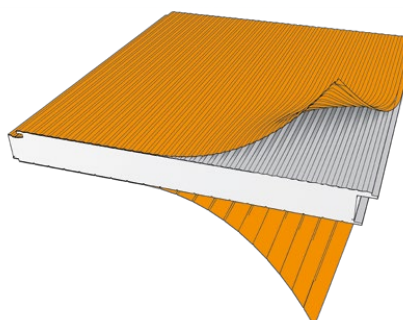

The beginning of the vertical installation is illustrated in **Fig. 19**.

The beginning of the horizontal installation is illustrated in **Fig. 20**.

Fig. 19

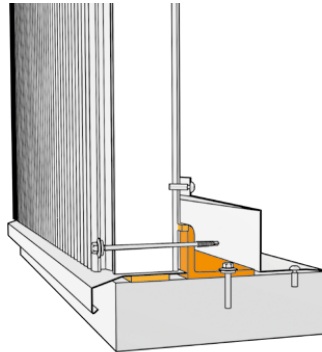
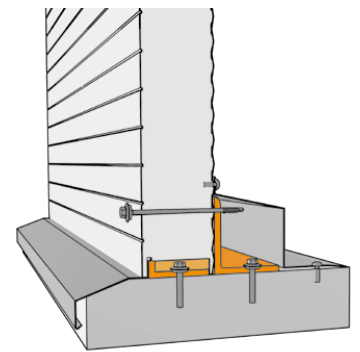
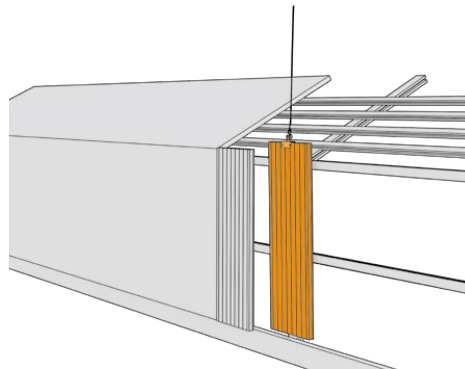

Fig. 20



- Example of the installation of sandwich panels in a vertical arrangement using panel lifting equipment.

Fig. 21



- The technique of joining the wall panels is tongue and groove, which significantly speeds up the installation of the subsequent panels.

Fig. 22

For a sandwich panel with a mineral wool core.

Fig. 23

For a sandwich panel with PUR and PIR core.

If wall panels with a CORE WOOL mineral wool core do not have a factory seal in the lock, it is permissible, after prior consultation with VSS, to apply a butyl sealant to the outer and inner sides of the panel in the lock before fixing the panels to the structure.

Fig. 22

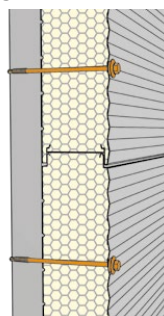

For a sandwich panel with a mineral wool core.

Fig. 23

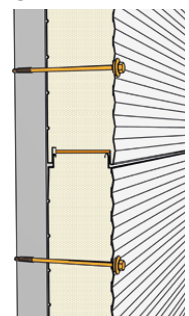

For a sandwich panel with PUR and PIR core.

When joining the sandwich panels lengthwise, it is essential to remember and fill in an expansion joint of at least 20 mm between them. In the case of a panel with a mineral wool core, fill it in with soft mineral wool, and in the case of a panel with a PUR/PIR core, with PUS sealing tape or installation foam, reducing the linear thermal bridge that will form there as much as possible. The panels should be fixed with screws at least 40 mm away from the edge of the panel and masked with metal parts, as shown in the sketches.

The minimum support width for such a solution is 120 mm.

For installation reasons, it is recommended that an angle bracket be fixed to facilitate positioning of the upper sandwich panel, both with mineral wool core and PUR/PIR core, as well as support for the starter element in the case of a panel with PUR/PIR core.

Fig. 24, 25



The standard joint gap between joined sandwich panels should be 3 mm ± 2 mm. However, in situations where the core of the panel is offset from its axis (which is permissible and in accordance with the standard, resulting from the specifics of the production), the priority is to ensure that the cores of the joined panels are in proper contact. In such cases, a deviation from the recommended gap in the locks is permissible - it may be other than 3 mm ± 2 mm, provided that the tightness and insulation continuity of the joint is maintained.

Fig. 24

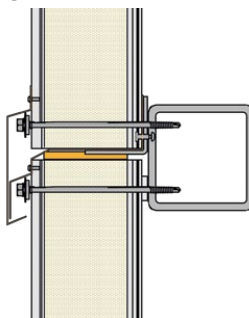
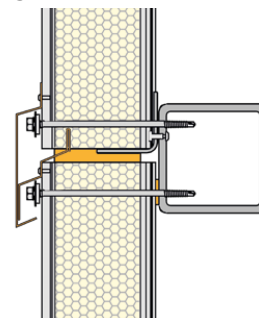

Fig. 25



INSTALLATION OF ROOF PANELS

Before starting the installation, it must always be checked that the width of the roof supports corresponds to the design.

- The installation of the panels starts by fixing the first panel in place. It is important to ensure that the installed panels, which are connected using locks according to the manufacturer's guidelines, maintain a straight and linear alignment. Otherwise, correct the first panel and only then start fixing the subsequent panels to the structure. The number and location of fasteners should be verified by the constructor, we usually assume 3 fasteners for the end supports **fig. 26** and 2 fasteners for the intermediate supports **fig. 27**.

- **Fig. 28** shows both how the sandwich panels are fixed to an intermediate support and the minimum support width, which is 60 mm.

- **Figure 29** shows both how the sandwich panel is fixed to the final support and the minimum width of the support, which is 40 mm.

Fig. 26

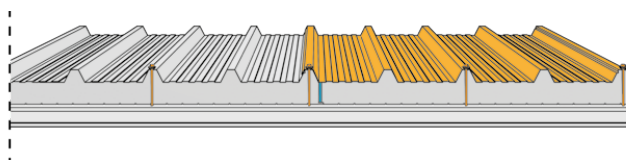

Fig. 27

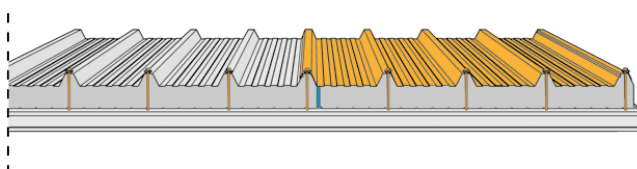

Fig. 28

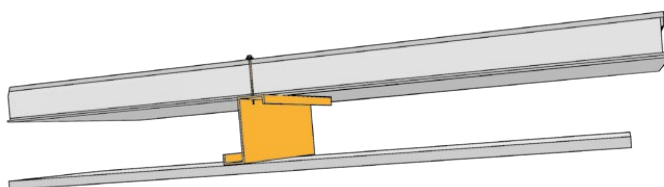
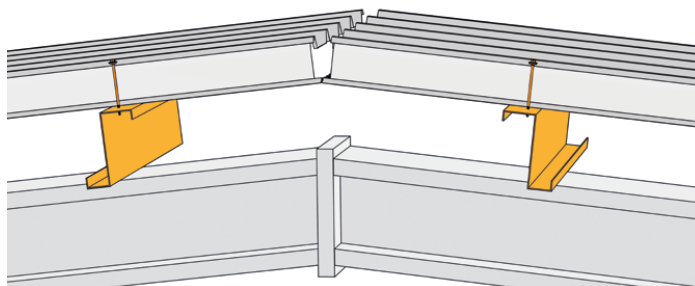
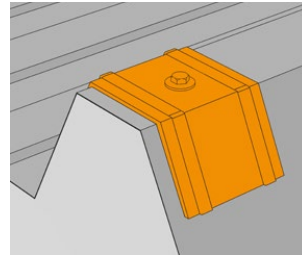

Fig. 29



- Brackets are recommended for the installation of roof panels. Their function is to distribute the pressure force of the screws evenly over a larger surface area and to ensure watertight connections.

Fig. 30



- The minimum pitch of a roof made of VSS composite panels is:
 - > 5% for roofs using continuous panels without joining lengths and without skylights,
 - > 7% for roofs using continuous panels with lengthwise joints or skylights.

Fig. 31, 32

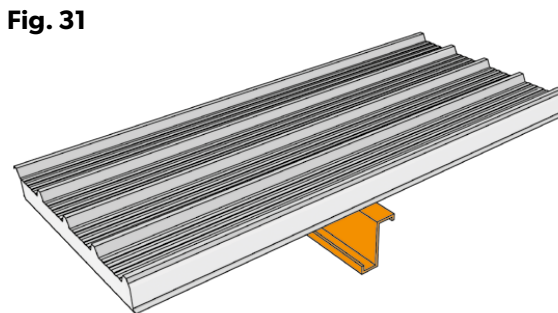
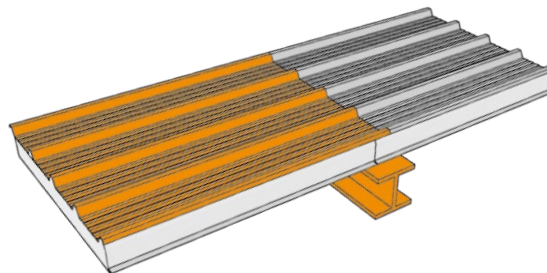

Fig. 32



- To ensure adequate tightness of the panel joint, an additional fastener should be used along the length of the joint, spaced at ~300 mm intervals or as recommended by the designer.

Fig. 33, 34, 35

Fig. 33

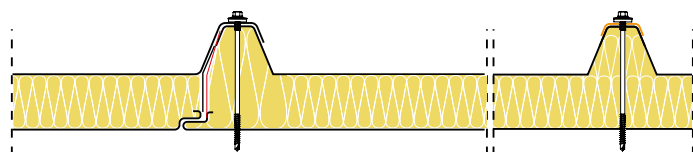

Fig. 34

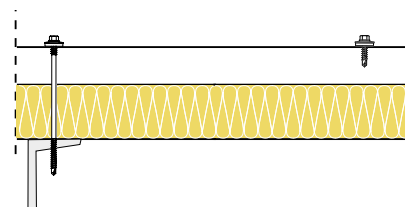
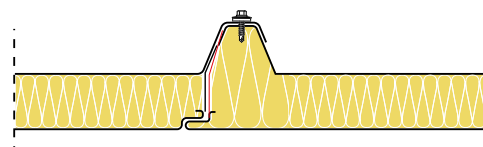

Fig. 35



The basic types of cutting of VSS composite panels are described below.

PUR / PIR roof sandwich panels can be manufactured with undercuts on the right or left side, depending on project requirements.

If the length of the roof slope exceeds the maximum length of the panel, panel joints must be made.

In this case, a basic cut of 50-300 mm should be made on the top (roof) plate, as required.

A basic cut can also be made in the lower panel to cover the eaves apron (50 mm is recommended).

Fig. 36

Fig. 36

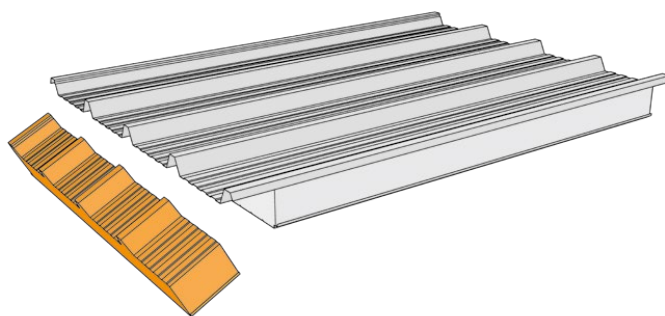
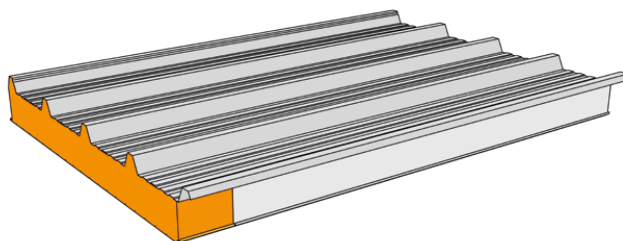

Depending on the laying of the so-called trapezoid (bare ridge), the panels are called right or left, which makes it easier to indicate how they are fitted.

When choosing the basic cuts, the direction of the panel should be clearly established, which is defined by the panels - left and right. Possible precipitation and wind directions should be taken into account for the direction of the installation.

Depending on the basic cut, VSS composite panels have the following installation directions:

- roof panels installed from right to left (right open ridge) - right-hand cut;
- roof panels installed from left to right (left open ridge) - left-hand cut.

Fig. 37 , 38, 39

Fig. 37

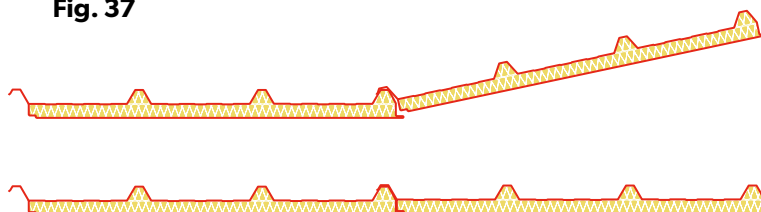

Fig. 38

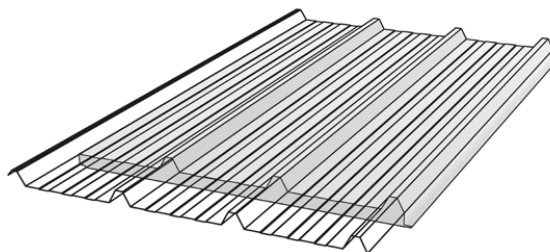
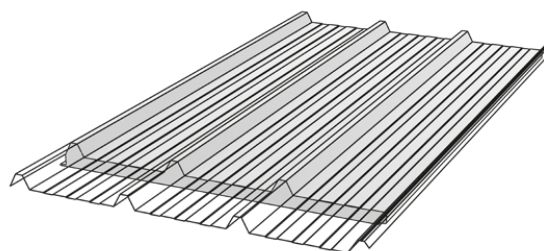

Fig. 39



The standard joint gap between joined sandwich panels should be 3 mm ± 2 mm. However, in situations where the core of the panel is offset from its axis (which is permissible and in accordance with the standard, resulting from the specifics of the production), the priority is to ensure that the cores of the joined panels are in proper contact. In such cases, a deviation from the recommended gap in the locks is permissible - it may be other than 3 mm ± 2 mm, provided that the tightness and insulation continuity of the joint is maintained.

The VSS production line enables factory application of a dedicated „BLUE TAPE“, which facilitates and speeds up the preparation of overlaps for connecting boards lengthwise.

Fig. 40



The use of BLUE TAPE is available as an option and must be confirmed by the customer when placing the order.

Fig. 40

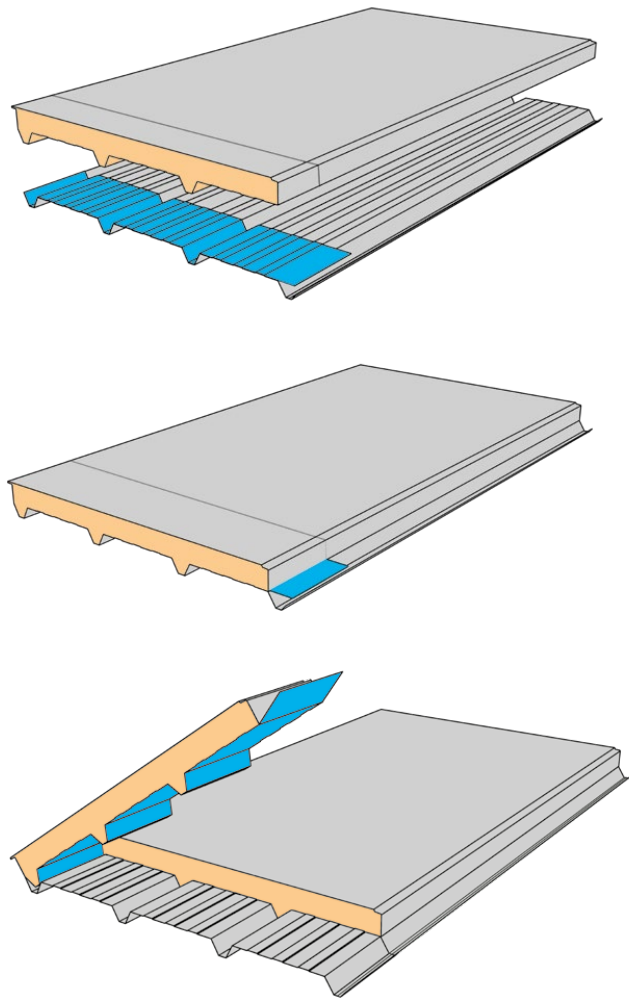

Determining the part where the notch is made is a very important step when preparing the notch list of the total length of the panels. It must take into account the size of the notch, as the type of notch determines the direction of the installation. When sandwich panels are manufactured with a predetermined cut, it is practically impossible to change the assembly, which creates enormous difficulty during the panel installation.

After the installation of the VSS roof sandwich panels, the following must be done:

- rivet the ridge flashing between the ridge purlins; **fig. 41**
- fill the cavity between the roof panels with polyurethane core with polyurethane foam; after the foam has hardened, cut off any leaks and apply a shaped seal (the so-called ridge seal) to the panels on both sides of the ridge;
- for roof panels with mineral wool core, fill the space between the panels with a butyl sealant and mineral wool;
- fasten the ridge flashing (so-called ridge cap) to the ridge of the panel with fasteners or tight rivets, and apply PES soundproofing to the ridge;
- apply the ridge flashing to the top of the ridge and fix it to the roof panel with fasteners.

The installation of the VSS roof panel eaves should be carried out as follows.

Variant I - PVC gutter:

- Drain water properly from the roof slope. To do this, the panels in the eaves should be terminated with a roof eave;
- Cut the core under the upper panel cladding using an electric drill with a minimum of 3000 rpm and an extended twist drill with a working length of min. 65 mm and a diameter of approx. 5 mm, then press in the mounting flashing and fasten it to the lower panel cladding;

Fig. 42, 43

- Fix the gutter hooks to the flashing so that they ensure the correct gradient of the gutter. Then push the gutter drip under the top cladding of the panel, rivet with sealing rivets and apply sealant along the strip;
- insert PVC gutters;
- place a trapezoidal roof closure element on the back of the panel at the ridge.

Variant II - steel gutter:

- water should be drained properly from the roof slope. For this purpose, the panels in the eaves should be terminated with a roof eave;
- Cut the core under the upper cladding of the panel using an electric drill with a minimum of 3000 rpm and an extended twist drill with a working length of min. 65 mm and a diameter of approx. 5 mm, then push in the eave and fasten it with the rivets;
- Apply roof eave and rivet it to the panel;
- Fix the gutter hooks to the flashing to ensure the correct gutter pitch is achieved, then push in the steel gutter and apply sealing compound along the roof eave;
- Place a trapezoidal roof closure element on the back of the panel at the ridge.

Fig. 41

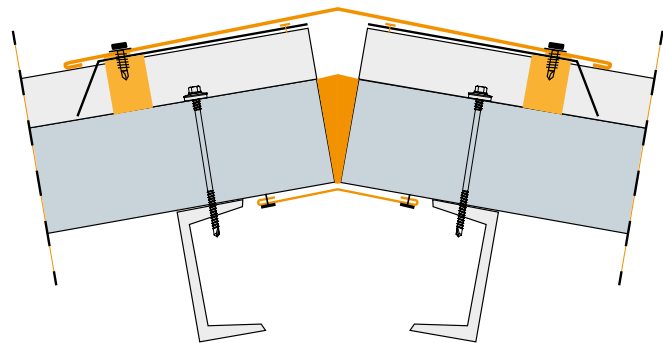

Fig. 42

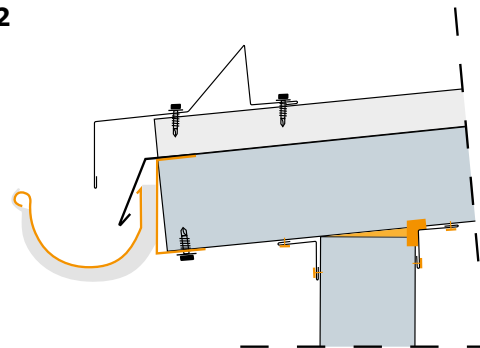
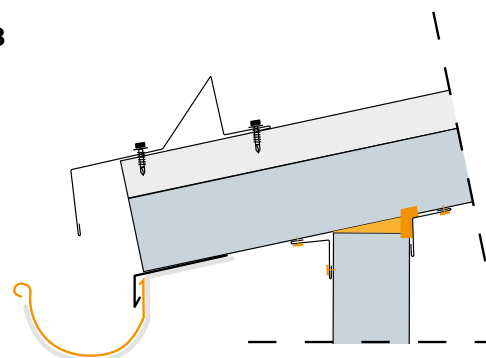

Fig. 43



INSTALLATION OF FLASHINGS

Method of joining the starting strip flashings together.

Fig. 44

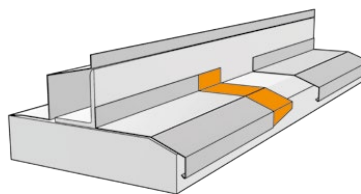

Place of contact between the masking element and the starting strip when the sandwich panels are joined horizontally.

Fig. 45

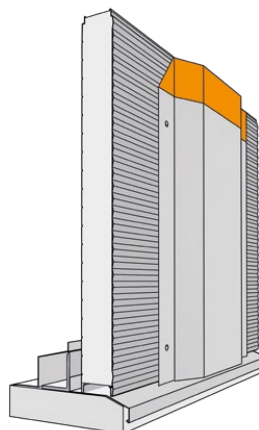

Method of making an external and internal corner from a part of the starting strip.

Fig. 46

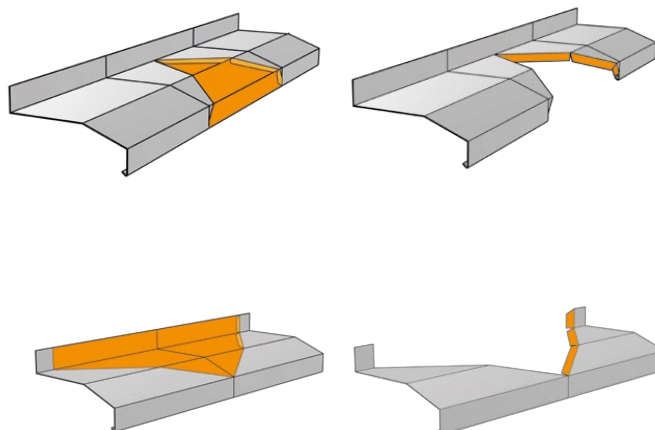

Joining along the length of two masking elements of a horizontally mounted composite panel joint.

Fig. 47

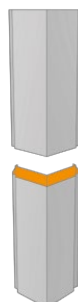

5. CLEANING AND MAINTENANCE OF SANDWICH PANELS.

Once the installation work has been completed and the protective film has been removed, any dirt present on the panels in the form of grease, dust or dirt should be removed. This should be done by hand, using a cotton cloth or sponge and a solution of water with a mild water-soluble detergent (pH ~7), and then rinsed with water. It is advisable to carry out this operation at a positive temperature.

1. Snow and dirt removal

When removing snow or dirt from the roof slope, special care must be taken so that the tools used do not damage the cladding of the sandwich panels. Leaves from trees and other debris deposited on roof slopes should be removed every year and, if necessary, even more frequently. Roof cavities and drainage systems should also be cleaned at least once a year. It is not permissible to leave loose fixtures, pieces of sheet metal, drilling splinters or other metal objects on the surface of the panels, posing a corrosion risk and also a danger to users - e.g. in the event of a fall from height.

2. Inspections

At least once a year, it is recommended that the surface of the sandwich panels and flashings be thoroughly inspected (especially in sheltered areas, e.g. eaves, panel/ flashing joints, panel edges). It should be borne in mind that the higher the corrosion aggressiveness of the environment, the more frequent and thorough the inspection should be. The fastening of panels and flashings should also be checked annually, as missing or damaged fasteners can cause leaks, dampness and ultimately damage to coatings. During the inspection, all damaged fasteners should be replaced while loosened ones should be tightened.

3. Cleaning the sandwich panel cladding

Cleaning the panel cladding surfaces is intended to remove visible dirt that detracts from the aesthetics of the façade and has a negative impact on the durability of the corrosion protection. In food industry facilities, where there is a requirement to ensure microbiological purity, it is necessary to use specialized cleaning agents and disinfectants at the same time. Several factors determine the applicability of a particular cleaner for sandwich panels:

- type of panel cladding and organic coating;
- frequency of cleaning;
- thoroughness of cleaning.

In cases where it is difficult to remove stains with water alone, use water with a detergent additive. Mild washing agents are recommended, well soluble in water with an acceptable pH of 4-9. After each washing, it is necessary to thoroughly rinse the detergent with clean water. In special cases where the use of industrial cleaning and disinfecting agents is necessary due to hygiene requirements, the recommendations of the cleaning agent manufacturer must be followed when cleaning the cladding. It is recommended to carry out a cleaning test (on a small area) to check whether the agent does not damage or soften the organic coating. Cleaning agents in the concentrations indicated by the manufacturer, with the appropriate potency and at a temperature not exceeding 30°C, should not remain in contact with the coating for longer than 30 minutes. The pressure of the clean water used for flushing must not exceed 5 MPa (50 bar) at the nozzle exit, and should not exceed 0.04 MPa at the point of impact of the water jet (such pressure produces a 5 MPa jet when the nozzle is positioned at a 15° angle at a distance of 20 to 30 cm from the wall). Rinsing should be done very thoroughly, starting at the top of the object so that all of the detergent is rinsed off. Remember to rinse the drainage systems (sewage system, gutters, etc.) thoroughly at the end. As a rule of thumb, the water temperature should not be higher than 30°C. The exception to this is when rinsing with water to wash off grease, when the water temperature can be temporarily increased to 50°C. Grease can be removed with a soft cloth and white spirit. Surfaces cleaned in this way must be rinsed immediately with clean water. The use of organic solvents or abrasive cleaners must be strictly avoided. Do not use steam cleaning or rinsing with water on the surface of the panels at temperatures below or equal to 0°C.



Modular roofing tiles
MODULAR SERIES



Compact roofing tiles
COMPACT SERIES



Steel roofing tiles
CLASSIC SERIES



Retro roof tiles
RETRO SERIES



Roof panels
PANEL SERIES



INTEGRATED
PV PANELS



Steel roof gutter system
INGURI



TRAPEZOIDAL
SHEETS



STRUCTURAL
PROFILES



FLAT METAL
SHEETS



FLASHINGS



ACCESORIES



Roof Sandwich
PANELS



Wall Sandwich
PANELS



Facade cladding
SKRIN, LINEA



Uncoiling and slitting
SERVICES



Flat sheets and cutting
SERVICES



PERFORATION
of sheets

